

# GOOD TREE NURSERY PRACTICES

PRACTICAL GUIDELINES FOR  
RESEARCH NURSERIES



INTERNATIONAL CENTRE FOR RESEARCH IN AGROFORESTRY

**GOOD  
TREE NURSERY  
PRACTICES**

**PRACTICAL GUIDELINES  
FOR RESEARCH  
NURSERIES**

**HANNAH JAENICKE**

INTERNATIONAL CENTRE FOR RESEARCH IN AGROFORESTRY

***Disclaimer***

*The mention of any product or trade name does not mean that the author or ICRAF endorses them or excludes equally suitable products.*

*In this publication, pesticides are mentioned. Pesticides can be harmful to humans, animals, desirable plants, fish or other wildlife if they are not handled properly. Recommended practices as described on the pesticide containers should always be followed.*

*Neither ICRAF nor the author assumes liability for any damage, injury or expense that may be incurred or suffered, resulting from the use of chemicals mentioned in this book.*

ISBN 92 9059 130 7

Cover photos: Hannah Jaenicke

Editing: Bernadette Hince

Design: Phyllis Ressler

Illustrations: Ndeithi Kariuki

©ICRAF 1999

International Centre for Research in Agroforestry

PO Box 30677

Nairobi, Kenya

tel+254 2 521 450, via USA +1 650 833 6645

fax +254 2 521 001, via USA +1 650 833 6646

email [icraf@cgiar.org](mailto:icraf@cgiar.org)

internet <http://www.cgiar.org/icraf>

Printed by: Majestic Printing Works

Nairobi, Kenya

# Contents

Foreword.....	4
Introduction.....	5
Acknowledgements.....	6
Section 1: Seedling quality.....	7
Targeting seedlings and seedling quality.....	7
Quality seed.....	9
Seedling development.....	12
Handling seedling variability.....	17
Further reading.....	20
Section 2: Containers.....	22
Types of containers.....	23
Further reading.....	28
Section 3: Substrates.....	30
Physical and chemical properties.....	30
Soil and soil-less media.....	34
Suggested mixes.....	41
Further reading.....	43
Section 4: Fertilizers.....	45
Organic fertilizers.....	47
Inorganic fertilizers.....	49
Further reading.....	54
Section 5: Nursery and plant hygiene.....	55
Actions to prevent nursery contamination.....	57
Actions to cure infected plants.....	63
Further reading.....	64
Section 6: Nursery environment and facilities.....	65
Nursery layout.....	66
Enclosed structures.....	66
Water.....	69
Light.....	70
Temperature.....	72
Gas exchange.....	72
Electricity.....	73
Further reading.....	73
Section 7: Nursery management.....	74
Plans and schedules.....	74
Staff training.....	77
Further reading.....	78
General reading.....	79
Glossary.....	81
Annex 1: Nursery suppliers.....	85
Annex 2: Useful Internet addresses.....	89
Index.....	91

# Foreword

In the coming decade, farmers in the tropics will plant millions of trees in their fields. Twenty years ago most new trees on farms would have been wildings, nurtured wherever they germinated. What will change is that more trees will be deliberately planted in chosen niches on farms. Some of these plantings will be through direct sowing but in general they will come from seedlings or rooted cuttings raised in a nursery.

Research today into the domestication and performance of hundreds of agroforestry tree species is accompanying efforts to see the results of our research reach more people. The starting point for this is the tree, and the starting point for the tree is the nursery.

A great deal has been published about tree nurseries, but it concentrates on commercial plantation species. In this volume, the author has incorporated ideas and experiences from her own work and that of partners dealing with agroforestry tree species, and findings from published literature, to produce an invaluable technical guide.

*Good tree nursery practices for research nurseries* is more than a checklist of do's and don't's for nursery managers and researchers. It presents concise but thorough information on all aspects of raising high-quality planting stock, with lists of contacts and nursery suppliers. In addition to general recipes and suggestions, tips are provided for developing specific nursery approaches to cater for the diversity of tree species, locations and nursery resources available.

By producing and using better quality tree seedlings in research nurseries, the results of such research will provide maximum benefit to small-scale farmers who are planting trees. Farmers are asking for tree stock with good survival rates, fast early growth and predictability of performance. Researchers experimenting to meet these aims need to use high-quality planting materials.

Greater recognition of the role of good tree nursery practices and quality tree seedlings in ensuring sustainable and profitable agroforestry systems is needed. This manual aims to promote such recognition among researchers. A companion volume, *Good tree nursery practices for community nurseries*, aims to do the same among farmers, NGOs and community groups. Let us hope that they and others change the common slogan of "plant a tree" to "plant a quality seedling".

*Tony Simons*  
*Domestication of agroforestry trees programme*  
*ICRAF*

# Introduction

Trees are central to our lives. We eat food and fruits from trees, we use paper made from wood pulp, tools with wooden handles, and medicine extracted from tree bark. We and our animals rest in their shade and we breathe their air: one large tree produces enough oxygen daily to supply a family of four. Trees are an integral part of agricultural landscapes and are playing increasingly important roles in income provision for rural households.

Many of the species that are coming onto the market out of tree domestication programmes are new — they have grown in the forests but nobody has raised them in a nursery before. However, all too often, nurseries operate with minimal inputs and outdated techniques, and produce poor seedlings. Disappointment about slow development or even seedling death is common, and many farmers have lost interest in tree planting out of frustration over bad planting material. If the tree nurseries fail to produce high-quality seedlings, deforestation and loss of valuable genetic resources will continue and will devastate our landscapes. We have a lot to learn about the requirements of these species and about their functions in agricultural systems. This is why we do agroforestry research.

Good and meaningful research depends on quality inputs and reproducible methods. That is what this book is about. It gives guidelines for uniformly high-quality seedling production. Although undomesticated germplasm often has a high variability, nursery managers have to guarantee that seedlings are produced under uniform and optimal conditions. Only then can a researcher attribute the variability clearly to the genetic differences of the seed. Only if healthy rootstock is produced, can successful grafting experiments be carried out. And only when we know the full potential of a new species or provenance, can we start assessing how well it might develop under adverse conditions.

Tree nurseries attached to research or plantation programmes differ in one important aspect from small-scale rural nurseries: they have — or ought to have — more resources, so that initial costs for investments are not as critical as they are for many rural nurseries. Therefore, keeping high quality standards can and should become the leading principle. These nurseries can demonstrate the beneficial effects of such investments to farmers. Structured planning and quality control, appropriate substrates and containers, nursery hygiene and good equipment — all necessary in good nursery operation — are discussed in this manual.

Not all of the suggestions presented here will fit a particular location. Every nursery has its own individual environment which requires special equipment to produce healthy seedlings. Every nursery has a unique target — planting sites, climate or clients which require special seedling quality standards and standard nursery practices. For different species, different nursery strategies are needed. This book provides information so that such strategies can be developed through simple experimentation. It is written primarily for nursery managers who are keen to improve an existing nursery by using good nursery practices for quality tree seedling production.



# Acknowledgements

This project was financed by the German Ministry for Economic Cooperation (BMZ), the German Agency for Technical Cooperation (GTZ) and the British Department for International Development (DFID). The Government of the Netherlands kindly contributed to the printing costs through its DSO (Direct Support to Training Institutions in Developing Countries) programme support to ICRAF's training materials activities.

Many people contributed to this publication. I acknowledge the valuable input of Jan Beniést, Doug Boland, Sammy Carsan, Richard Coe, Ian Dawson, Phil Harris, Norman Jones, Samuel N Koffa, Ann Mbora, Deborah Mugada, Naomi Mungai, Benson Mwanthi, Amadou Niang, Tony Simons, August Temu, Margaret Thiong'o, Eucabeth Opande, James Were and Kevyn Wightman.

## Section 1: Seedling quality

This chapter describes what we mean by 'quality' seedlings. Here, we discuss targeting seedlings to the conditions you expect at the site where you will plant them. We give ways to monitor plant development and describe simple routines that help to handle planting stock or to reduce variation amongst seedlings. Feedback provided by experimenters and farmers is important in improving a nursery's standards.

### *Targeting seedlings and seedling quality*

The clients and the conditions at the site where the seedlings will be planted (the 'outplanting' site) determine what kind of seedling is needed. A researcher will require planting stock raised under uniform conditions to ensure that research results are not confounded by the status of the seedlings. Small-scale farmers, on the other hand, who often cannot provide the care to a tree that might be desirable, need seedlings that can survive under hard, often dry and nutrient-deficient conditions. The best looking seedling at the nursery is worthless if it does not survive and grow after planting out. 'Targeting' seedling production to the anticipated field site is an important step in producing strong healthy seedlings. It is wrong to think that seedlings destined for harsh environments, for example arid sites, should be raised under harsh conditions in the nursery. However, they do need to be hardened-off— gradually prepared for 'real-life' conditions, for example by withholding water from time to time — **after** they have developed a strong and healthy root system. Insufficient care in the nursery leads to weak and retarded plants with small root systems that will not survive in a harsh environment.

Targeting' seedling production to the anticipated field site is an important step in producing strong healthy seedlings.

Quality seedlings targeted for different sites may look different from each other but they all have one thing in common: a well-developed root system with many root tips from which new roots can quickly develop. In areas with adverse environments, such as dry, flooded, saline or nutrient-deficient sites,



## Section 1

only well-developed plants have a good chance of survival. For dry areas produce seedlings with a deeper root system. For weedy sites larger plants are better — they can outgrow weeds quickly.

*Seedling quality* is a concept, widely used in forestry, which has received considerable attention in Europe and the US. It is important because afforestation seedlings cannot receive the same care that may be given to individual ornamental or fruit trees. After they are planted, the seedlings have to survive without irrigation or fertilizer, and this is often the case in tropical small-holder agroforestry sites too. Many studies have shown that field survival and productivity are related to the quality of the seedlings used.

**Seedling quality depends on:**

- the ability to produce new roots quickly
- the speed with which seedlings get anchored in the ground, and start assimilating and growing after planting out
- a well-developed root system
- sun-adapted foliage
- a large root collar diameter
- a balanced shoot:root ratio
- good carbohydrate reserves
- an optimum mineral nutrition content
- the establishment of adequate mycorrhizal or *Rhizobium* infection

Many seedling quality characteristics, such as the shoot:root ratio, are difficult to observe and/or require destructive sampling. The shoot:root ratio is an important measure for seedling survival. It relates the transpiring area (shoot) to the water absorbing area (roots). It is usually measured by determining root and shoot dry weights. A good ratio — one which indicates a healthy plant — is 1:1 to 1:2 shoot:root mass.

A less rigorous, but non-destructive, index is the 'sturdiness quotient', which compares height (in cm) over root collar diameter (in mm). A small quotient indicates a sturdy plant with a higher expected chance of survival, especially on windy or dry sites. A sturdiness quotient higher than 6 is undesirable.

For each nursery population, measure the root and shoot dry weight of a few plants at random to get an idea of the general population quality. Of course the data you get will be meaningless unless you correlate it with field survival at a later stage to see for each species and site how well these simple measurements relate to the survival and growth of the seedlings.

Although plant quality indices have been developed mostly for species in the northern hemisphere and have not been tested on tropical species, they can still give an indication of the quality of tropical agroforestry species.

Nursery bed density, shading, pricking out techniques, seedling size at planting, watering and fertilizing before and after planting out — all these have significant and long-lasting effects on seedling quality and subsequent tree development, insect and pest resistance, and tolerance to environmental stresses such as drought.

### *Quality seed*

Seedling quality also depends on the seed used. The quality of seed planted in the nursery is of crucial importance, since seeds are the most basic input into any planting programme. It is therefore necessary to pay proper attention to quality issues when procuring and subsequently storing tree seed until planting.

### *Getting your seed*

Seed for a planting programme may be obtained in different ways. You can collect it directly from local stands of a species (such sources include native or naturalized stands and stands established specifically for seed production). Alternatively, you can order it from a commercial or non-commercial seed supplier. Most nursery managers get their seed from seed suppliers. When ordering seed from a supplier, always pay attention to the genetic quality of seed. Genetic quality relates to the origin (provenance) of seed and its genetic diversity.

The quality of seed planted in the nursery is of crucial importance, since seeds are the most basic input into any planting programme.

## Section 1

Wherever  
you can,  
best  
your  
particular  
planting  
purpose.

**Origin** is important because most trees exhibit considerable intraspecific genetic variation, so the performance of different provenances (origins) of the same species may vary widely. It is important, wherever you can, to get the best provenance for your particular planting purpose.

**Genetic base** (the diversity of genes) is especially important when seed is collected, for two reasons. First, a wide genetic base (such as a large number of varieties) gives flexibility to changing user requirements and environmental conditions. Second, since most trees are predominantly outbreeding (they produce seed by cross-fertilization, rather than self-pollination), a wide base provides protection against a future loss in performance through inbreeding depression (a decrease in vigour common to outbreeding species when their genetic base is too narrow).

If seed is collected directly from a local stand, the same issues of quality should be considered. To ensure a wide genetic base, **never** collect seed from a single tree, always collect your seed from a number of trees (normally at least 30). Note the species, origin, collector and date of collection (as a minimum), for future reference. Give this information to any other person you are giving the seed to. It is important to collect mature seed, because immature seed has low viability and storage life. With many species, seed is mature

#### When ordering seed from a supplier

Choose a supplier who provides good documentation on his or her seed (this can be judged by asking suppliers for their seed catalogues). The more information a supplier can provide about the seed, including provenance, source (natural, naturalized or planted stand), collection method and collector, the better your selection of material will be and the higher your chances of getting quality planting material.

Specify the environment in which, and purpose for which, seed will be planted, and ask the supplier to provide the best possible material.

Remember, it is important for the supplier to specify the origin of seed, so that you can get more seed of the same provenance in the future (from the same or other suppliers), if it performs well.

when it can no longer be crushed between your thumb and forefinger, when the fruits begin to split open (for example, legumes) or when the colour of seed changes. Seed can be cut to check the presence of a mature embryo and endosperm. After collection, follow proper procedures for processing the seed.

### After collection

For most species, **extract** seed from fruit as soon as possible. The method used will depend on the species. For many legumes, pods can be dried in the sun for two days and then rubbed across a coarse wire mesh through which seed falls. The extraction method used should not damage seed so that a significant loss in viability occurs. During extraction, remove impurities (for example, diseased or partly eaten seed, contaminating seed, soil, chaff and insects) by winnowing or hand-sorting.

After extraction, most seed should be **dried** further before storage. Generally, the lower the moisture of seed, the longer it can be stored. Normally, seed with a moisture content of 10% or less will maintain high viability for several years, if stored correctly. Sun drying seed for two to three days generally reduces moisture to an acceptable level, although more time is needed for large seed. Spread seed on raised beds to help air circulate, and shade the beds from strong sunlight (move seed into the shade for around two hours at midday).

During processing, the viability and purity of seed is normally **tested**. *Viability* is the percentage of germinating seed in a seedlot and is measured by germinating seed under conditions (including any pre-treatments such as nicking or soaking in hot-water) that would normally be applied during germination. This provides a reference level of germination for users. *Purity* is the percentage by weight of pure seed in a sample and is estimated by weighing a sample of seed before and after the removal of impurities. Record particular impurities, such as contaminating seed. The International Seed Testing Association (ISTA) has published guidelines for seed testing that qualified seed suppliers should adhere to.

- **Label** seed properly during processing and storage. An unidentified seedlot is almost worthless. As a minimum, seed should be labelled with the species name, original collection source, production location, collection date, producer and viability.

## Section 1

***Seed storage***

After you obtain your seed, you need to store it in the correct conditions in the interval before planting, to maintain its physiological quality. This will ensure that maximum viability is maintained. The supplier should specify the proper conditions for storage of seed. Normally, orthodox seed, which can be stored without losing viability for a long time, should be kept cool, dry and dark in airtight containers (such as plastic or glass bottles with screw-tight lids, or hermetically-sealed foil sachets). If possible, orthodox seed should be stored in a refrigerator. For recalcitrant seed, storage is more problematic. Seed is viable for only a short time and, whenever possible, should be planted out immediately. If this is not possible, storage at 10 to 15°C in humid conditions, for example in moist sawdust, may extend longevity.

***Seedling development***

There are three phases in seedling development:

- establishment
- production
- hardening

The establishment phase includes seed germination and first root growth. The production phase is manifested by rapid shoot growth. During the hardening phase, seedlings are gradually accustomed to field conditions.

***Establishment***

Various pre-treatments can be used to accelerate the start of germination and/or to shorten the germination period for all seeds so that germination is uniform rather than scattered over a long period of time. Which method to use depends on the species and the seed: large, hard seeds might require mechanical nicking and soaking, small seeds might only need to be soaked. If information is not available, carry out a few simple tests.

**Most common seed pre-treatment methods**

- soaking in cold water for 12, 24 or 48 hours
- immersion in hot (70°C) water, letting cool and soaking for 12, 24 or 48 hours
- nicking/partial or complete removal of seed coat

Whenever possible, sow seeds directly into containers or a bare-root nursery bed. Germinating seeds in germination trays or beds and pricking them out later can lead to severe root deformities unless it is done carefully (see box on page 14). If the use of germination trays is absolutely necessary, for example because seeds are extremely small or sensitive, always sow in several trays. This will minimize the risk of losing all seeds due to unforeseen problems, such as disease, flooding or drying out of the tray. If you do need to prick out, do it as early as possible after germination for most species. Only very tender seedlings, such as *Eucalyptus*, need to have the first true leaf pair developed before pricking out. Avoid letting the roots grow too long and developing side roots, or they will be damaged when transplanting. Especially with bigger seeds, transplanting can be done as soon as the root begins to emerge.

Whenever possible, sow seeds directly into containers or a bare-root nursery bed.

If pricking out is done for an experiment, ensure that seedlings are pricked out block by block, and that each person pricking out does a complete block. This will ensure that experimental treatment effects are not confounded by nursery practices.

Inoculation with mycorrhizal fungi or *Rhizobium* bacteria is necessary for good plant development of most agroforestry tree species. It can increase plant disease resistance and help alleviate plant stress by enhancing the plant's water and nutrient uptake. Early infection with mycorrhiza can also increase the propagation success of cuttings and seedlings. It is especially important that mycorrhizal and *Rhizobium* associations are well-established when you are producing seedlings for acid or degraded soils.

Ideally, get the inoculum from a reputable supplier. If this is not possible you can take advantage of the fact that spores and mycelia of mycorrhizal fungi are abundant in the soil around established trees. Inoculation is easy when some of this soil can be mixed into the propagation substrate. Usually, a small amount (5-10% of the total mixture) of topsoil is sufficient. However, as we discuss in section 5, topsoil can introduce soil-borne pathogens into the nursery. Carry out a preliminary experiment to see whether that will be the case with the topsoil of your choice. If the soil is contaminated with pathogens, you will need to acquire sterile inoculum from a commercial supplier (see Annex 1).

**Steps in pricking out— these apply for both container and bare-root beds**

1. Fill the containers well in advance with a good potting substrate and water the day before pricking out.
2. Water the germination tray well the day before pricking out.
3. Lift the seedlings carefully, holding them by the cotyledons, after loosening the substrate, so that the soft stem does not get damaged.
4. Prepare only as many seedlings as you can pot within 30 minutes; put the seedlings into a container with water or cover them with wet paper or cloth and keep them in the shade until needed.
5. Make a hole in the substrate using a small stick. Ensure that the hole is in the centre of the container — or that holes are equally spaced in the case of bare-root beds — and that it is longer than the roots of the seedling to be potted. This can be done in advance of pricking out to speed up the operation.
6. If the roots have already grown longer than the container's depth, cut tap root using a sharp and clean knife.
7. Put the seedling into the hole, ensuring the roots are not curled; insert the seedling a bit deeper than necessary, then lift it up again to straighten the roots.
8. Press substrate firmly around the seedling and water thoroughly to avoid air pockets in the substrate.
9. Keep filled containers under shade for at least two weeks.

*Production*

As soon as a seedling is established, either a few days after germination or after pricking out, both roots and shoots begin growing rapidly. This phase is as important as the establishment phase. Root development is important for good inoculation with symbionts, for efficient nutrient uptake and for outplanting success. The number of fine roots with growing points largely determines the ability of the seedling to recover and start growing after planting out. If the root system is small and/or distorted, the tree cannot anchor itself sufficiently in the ground and is prone to wind-throw or lodging when waterlogged.

The appearance of a healthy root system is of course different for species with a strong tap root, than it is for those with a mass of shallow roots. However, most tree seedlings have a straight, slightly tapering main root and a large



**Labelling nursery stock**

From the moment seeds are sown, they should be carefully labelled. Each seed lot needs to be identified clearly, with species name and code, date of sowing and later treatments on the label. Put two labels on each batch, one at the beginning of the row and one at the end. If smaller numbers of seedlings are produced, label each plant individually with a paper, plastic or metal tag. **Careful labelling is never a waste of time!**

mass of fibrous roots. Healthy roots are not bent, crossing or injured. Knotted and bent roots are common in plants that have been left in the nursery too long or have been pricked out without the necessary care. These plants cannot survive in the field because the crossing roots may eventually strangle the tree or they may die back and become vulnerable to disease and termite attacks. It is worth sacrificing a few plants every now and then to have a look at what usually remains unseen: the roots of the seedlings (see figure below). Compare with the healthy root system of the seedling on the right. You can carry this through to field plantings — dig up and inspect trees after months or years to see how the root system has developed. This is especially important when a planting has failed. When the plants are uprooted, take the time to examine the root systems. You might be surprised how often unsuccessful tree development can be attributed to root deformities.

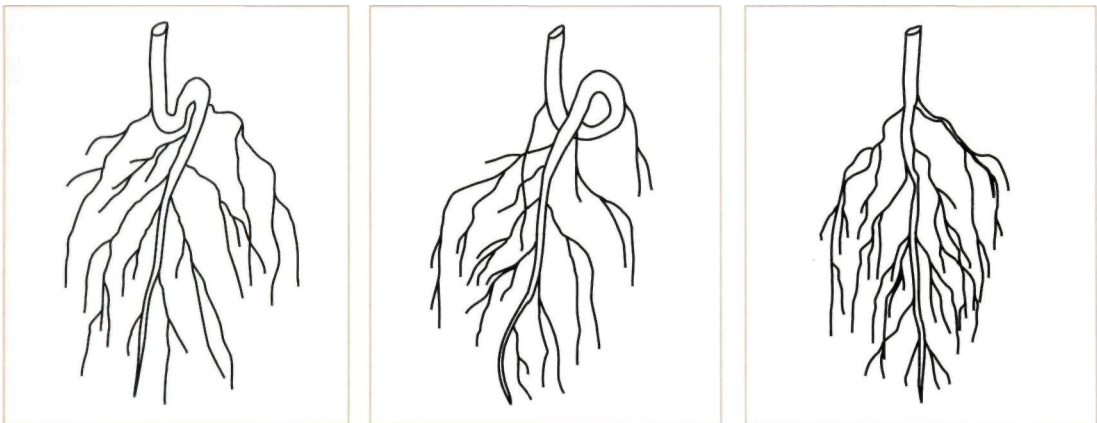

Examples of bent and looped seedling root systems.

Compare with the healthy root system of the seedling on the right.

## Section 1

*Hardening and planting out*

Seedlings need to get accustomed to the conditions at a planting site. Therefore, about 4–6 weeks before planting out, start hardening them by reducing watering gradually to once a week and by gradually removing the shading.

Plant seedlings out as soon as they have reached their optimum size. This varies with the species and the site, but it will usually be a height of 15–30 cm. It can be much larger for some slow-growing species, or when there is strong weed competition at the planting site. Do not leave seedlings in the nursery into the next season. Often, late rains, high workloads and other obstacles delay plantings. If this is anticipated you can try to slow down plant

Overgrown plants will have a very slow start in the field. They are prone to insect attack, drought and wind-throw because they have a poor root system. They will never catch up.

**Signs of overgrown plants are**

- lack of leaves, as old leaves fall and young ones are not produced
- a root system that lacks young, fibrous roots
- the tap root is often grown into the ground
- root deformities, for example roots coiling at the bottom of the bag
- lignification of the whole stem
- very short tip internodes but in general a tall, thin stem.

development. For example, when producing plants in containers, delay potting-on into bigger containers, or stop fertilizing. These are only temporary solutions, because the quality of the planting stock will deteriorate considerably if it is left too long in the nursery. If you know that planting will be delayed for a whole season, consider re-sowing.

A very important point which is unfortunately often overlooked is that **feedback** from scientists carrying out long-term research and from farmers should be sought and used for further improvement of plant quality. Client feedback is important for the fine-tuning of nursery operations. Try to visit field sites and experiments in the years after planting out, in order to see the effects of particular nursery practices. In addition, collect data on a regular basis to allow evaluations and possibly amendments of current nursery practices.

When you are in the field make the following observations for each tree: is the tree healthy, dead, unhealthy or missing? If so, what are the reasons: drought, cattle, rodents, insects, loosely planted (soil not compacted), shallow planted (holes not deep enough), spiral roots, planted too deep, 'J' root (bent root), small seedling, fire, vandalism? Observe the site conditions, too: is there shallow soil, is it rocky, nutrient deficient or acid?

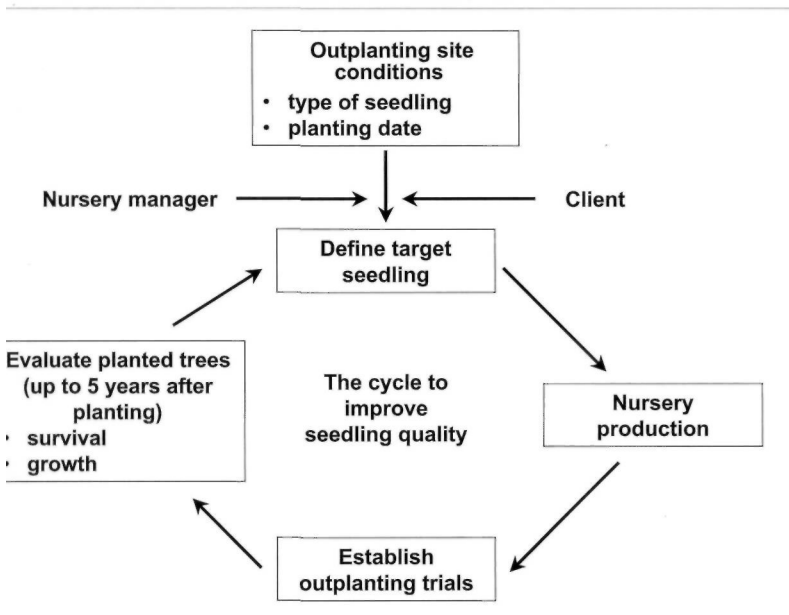

### *Handling seedling variability*

Every plant population has some degree of variation. This can be greatest for populations which have not undergone any domestication. Since few agroforestry tree species have undergone any significant domestication there will be wide variation in the size and quality of seedlings. This variation is still visible in the field many years after planting.

Although much agroforestry research focuses on determining and utilizing the variation within populations, an important prerequisite for some research is **uniformity** of planting stock. For example, an experiment with the aim of comparing management practices will give more precise results if variation in the seedlings used is minimized. How can you ensure that relatively

Improved and standardized nursery practices can help deliver more uniform planting material.

uniform populations leave the nursery? And how can researchers who are interested in the genetic variability itself handle variable germplasm without losing information?

Uniformity of seedlings from non-domesticated seed sources can be improved by rigorously **culling** the population before the plants leave the nursery. Culling is the removal of weak, diseased, or overgrown plants. It is

**Calculating variation**

Two blocks of a *Sesbania sesban* experiment show different CVs. In block 1 the CV is 25.9%, in block 2 it is 29.6%. Use various ways of setting culling targets to reduce the variability:

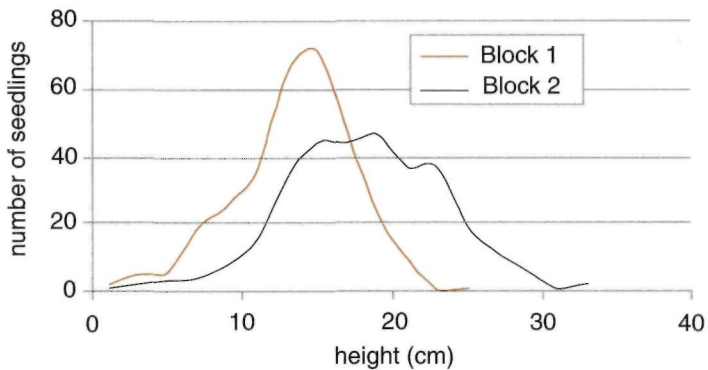

block 1	number of seedlings	average height	SD	CV%
original	315	15.5	3.88	25.0
cull 10% at both ends	251	15.6	2.52	16.1
cull 15% at both ends	221	15.7	2.09	13.3
block 2	number of seedlings	average height	SD	CV%
original	315	18.0	5.25	29.1
cull 10% at both ends	251	18.0	3.48	19.3
cull 15% at both ends	221	18.0	3.02	16.8

essential to set culling targets to reduce the variation in experimental plots in a reproducible way without depending on nursery staff to choose plants to discard (as they are usually very reluctant to discard any plants, especially those that are above average in size), and without significantly increasing costs. Remove unwanted seedlings early on to achieve a relatively homogeneous nursery population. If necessary, cull the plants again before seedlings are planted out.

It is not difficult to check a plant population for traits such as height, collar diameter and growth form, if you know the mean and standard deviation. You can easily get these by using a simple pocket calculator. One way of describing the variability is by using the **coefficient of variation** (CV). The CV is more useful than the standard deviation, because CV is independent of the measured units (cm, mm, etc.) This allows a better comparison of variability than standard deviation allows. CV is calculated as follows: standard deviation (SD) divided by sample mean = CV. This figure is multiplied by 100 and expressed as a percentage. The smaller the CV, the more uniform the population.

Of course, culling the extremes is not the only answer to improving population homogeneity. Improved and standardized nursery practices can help deliver more uniform planting material.

### *Recommended nursery practices when assessing variability*

Sometimes you might specifically want to assess the variability of the germplasm, for example in provenance trials. In this case, you will not want to rigorously cull. Grow the seedlings in the nursery in several blocks, and keep these together in the field. By doing this, variation that already appears in the nursery, for example slow growth due to shading of a particular nursery bed, is retained in the field and you do not mix these environmental effects with important genetic information.

You can distinguish genetic variability from nursery effects by transferring complete nursery blocks into the field.

When culling is necessary in a provenance test, for example to remove severely retarded seedlings, it is especially important that it is done at a low level, separately for each provenance. This will avoid selecting against provenances with a different development pattern than the majority, possibly resulting in the loss of valuable germplasm.

*Further reading*

- Bongkik M bin and Powell GR. 1996. Direct sowing of mangium into bags versus transplanting of germinants. In: Yapa AC (ed.). Proceedings of the International Symposium on Recent Advances in Tropical Tree Seed Technology and Planting Stock Production. Muak-Lek, Saraburi, Thailand: ASEAN Forest Tree Seed Centre. 206-212.
- Bumatay EC, Mende EIM and Quimio J. 1996. The effect of age and hardening arrangements in beds on the growth on *Acacia mangium* and *Acacia auriculiformis* in the nursery. In: Yapa AC (ed.). Proceedings of the International Symposium on Recent Advances in Tropical Tree Seed Technology and Planting Stock Production. Muak-Lek, Saraburi, Thailand: ASEAN Forest Tree Seed Centre. 126-129.
- Capon B. 1992. Botany for gardeners. An introduction and guide. London, UK: BT Batsford Ltd. 220 pp.
- Davidson J. 1996. Off site and out of sight! How bad cultural practices are offsetting genetic gains in forestry. In: Dieters MJ, Matheson AC, Nikles DG, Harwood CE and Walker SM. (eds). Tree improvement for sustainable tropical forestry. Proceedings, Queensland Forest Research Institute Conference. Caloundra, Queensland, Australia. 288-294.
- Dawson I and Were J. 1997. Collecting germplasm from trees — some guidelines. *Agroforestry Today* 9(2): 6-9.
- Dawson I and Were J. 1998. Ordering seed — some guidelines. *Agroforestry Today* 10(1): 8-11.
- Dierauf TA and Garner JW. 1996. Effect of initial root collar diameter on survival and growth of yellow poplar seedlings over 17 years. *Tree Planters' Notes* 47(1): 30-33.
- Duryea ML. (ed.) 1985. Evaluating seedling quality: principles, procedures, and predictive abilities of major tests. Portland, Oregon, USA: Oregon State University. 143 pp.
- Evans J. 1982. *Plantation forestry in the tropics*. Oxford Science Publications. Oxford, UK: Oxford University Press. 472 pp.
- Hawkins BJ. 1996. Planting stock quality assessment. In: Yapa AC (ed.). Proceedings of the International Symposium on Recent Advances in Tropical Tree Seed Technology and Planting Stock Production. Muak-Lek, Saraburi, Thailand: ASEAN Forest Tree Seed Centre. 107-111.

- International Seed Testing Association (ISTA). 1996. International rules for seed testing. Rules 1996. Seed Science and Technology vol. 24, Supplement. Zurich, Switzerland: ISTA. 335 pp.
- Jones N. 1993. Essentials of good planting stock. Forests and Forestry Technical Bulletin Number 2. Washington, DC, USA: World Bank/AGRNR. 7 pp.
- Josiah SJ and Jones N. 1992. Root trainers in seedling production systems for tropical forestry and agroforestry. Washington, DC, USA: World Bank. Asia Technical Department. Agriculture Division. 54 pp.
- Landis TD, Tinus RW, McDonald SE and Barnett JR 1994. Nursery planning, development and management, vol. 1, The container tree nursery manual. Agriculture Handbook 674. Washington, DC: US Department of Agriculture, Forest Service. 188 pp.
- Neumann RW and Landis TD. 1995. Benefits and techniques for evaluating outplanting success. In: Landis, TD and Cregg B (technical coordinators.) National proceedings, Forest, and Conservation Nursery Associations. General Technical Report PNW-GTR-365. Portland, Oregon, USA: US Department of Agriculture, Forest Service, Pacific Northwest Research Station. 36-43.
- Reid RK. 1991. First-year seedling field survival and growth as influenced by planting stock type. Haiti Agroforestry Research Project. South-East Consortium for International Development (SECID)/Auburn University Agroforestry Report no. 26.64 pp.
- Ritchie GA. 1984. Assessing seedling quality. In: Duryea ML and Landis TD (eds). Forest nursery manual: production of bare-root seedlings. The Hague/Boston/Lancaster: Martinus Nijhoff/Dr W Junk Publishers. 243-259.
- Thompson BE. 1985. Seedling morphological evaluation—what you can tell by looking. In: Duryea ML. (ed.), Evaluating seedling quality: principles, procedures, and predictive abilities of major tests. Portland, Oregon, USA: Oregon State University. 59-71.
- Valli I. 1996. Production of high quality seedlings in central nurseries in Indonesia. In: Yapa AC (ed.). Proceedings of the International Symposium on Recent Advances in Tropical Tree Seed Technology and Planting Stock Production. Muak-Lek, Saraburi, Thailand: ASEAN Forest Tree Seed Centre. 130-135.
- Zobel BJ, van Wyk G and Stahl P. 1987. Growing exotic forests. New York, USA: J Wiley and Sons. 508 pp.



## Section 2: Containers

Most agroforestry tree nurseries either produce bare-rooted seedlings or use polythene bags. We recommend that in a research nursery containers are used. However, polybags often restrict the root growth, and roots curl at the bottom or grow into the ground, resulting in weak or injured plants. We discuss root trainer systems as a modern alternative.

As a nursery manager, you have to decide whether to operate a bare-root nursery or a container nursery. Your decision depends mainly on the species and the environment. Economic considerations also play a role.

	<b>bare-root nursery</b>	<b>container nursery</b>
<b>water</b>	requires frequent watering	has moderate water requirements
<b>soil conditions</b>	needs excellent soil	soil quality is not critical
<b>land requirements</b>	needs large area of land because plants are grown at lower densities	can occupy a smaller area because of higher densities and lower culling rates
<b>plant hygiene</b>	soil-borne pests and diseases may become a problem	spread of disease can be better contained and controlled
<b>symbionts</b>	mycorrhiza and other symbionts may be present	specific mycorrhiza and other symbionts may need to be added to substrate
<b>seedling handling</b>	bare-root seedlings are relatively intolerant to physical abuse and mishandling	container seedlings are relatively tolerant to physical abuse and mishandling
<b>root pruning</b>	necessary and labour intensive	unnecessary if root trainers provide air pruning
<b>outplanting</b>	seedlings suffer outplanting stress; they are more suitable for better sites	seedlings are more tolerant to outplanting stress and are suitable for poorer sites

Bare-root nurseries are often recommended for on-farm nurseries because of the smaller capital investment needed. For a research nursery, always consider containerized systems unless you need bare-rooted systems for research — for example when studying the suitability of a species or nursery practice for on-farm production. Always relate the costs of establishing a container nursery to the improved quality and value of the nursery stock. This is particularly relevant for nurseries in research projects where costs are less critical.

For a research nursery, always consider containerized systems unless you need bare-rooted systems for research.

### *Types of containers*

Containers for plant propagation come in various forms, sizes, and in different materials — polystyrene, polyethylene, fibre or paper. New forms and materials are constantly being developed and tested. The type of container selected depends on the plants to be raised, their purpose and size. For example, in India's Andhra Pradesh state, the forest departments prefer large (at least 500 ml) polybags for fruit trees (grafted tamarind, emblica, custard apple, etc.) but use smaller (90 and 150 ml) root trainers for pulp or timber species.

A common problem with all containers is the substrate—this is covered in the following section. However, it is important to note that in developing countries the most commonly used substrates are soil and sand-based mixtures which are unsuitable for the development of an extensive fibrous root system.

**Polybags** are the containers most commonly used in tree nurseries in developing countries. They are usually made of black polyethylene and have several drainage holes at the bottom (if they don't, holes can be made using a paper punch). **Polysleeves** made from the same material are cut from a continuous roll and have no bottom. Both types are often locally made and therefore cheap (the most common sizes cost about a fifth to a third of a US cent per bag), and readily obtained in most countries. They come in various gauges and volumes between 0.3 and 45 litres.

A common problem with polybags is that plant roots tend to grow in spirals once they hit the smooth inner surface. This will inevitably lead to plants with restricted growth, poor resistance to stress and wind-throw and even early dieback due to ensnarled root masses or pathogens. This is a major drawback in the use of the conventional polybags. Because of their open bottom,

## Section 2

polysleeves allow for air pruning when placed on raised propagation beds, for example on a thick layer of gravel. But they are less resilient in transport, because the potting substrate can easily fall out and damage the roots. Polysleeves should never be placed straight onto soil because roots will grow into the ground and the main roots break off when you lift the plants.

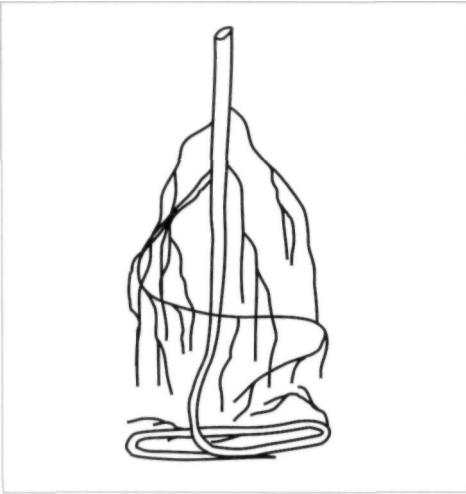

Bags or sleeves are not very durable and can break prematurely. For plants with a long nursery cycle, this can be a problem. They are normally used only once. The discarded polybags and polysleeves are a problem for nursery waste management, as they do not decay and are often burned, producing serious air pollution.

**Jiffy® pots** are made from compressed peat and need to be filled with a growth substrate. Roots can easily penetrate the container walls, so root curling does not occur. The seedling is planted together with the pot which is biodegradable. **Jiffy® pellets** are made from compressed peat and held together with a biodegradable net. They are pot and growth substrate in one. Upon use, they are irrigated and expand to approximately 5-10 cm height. Seeds or cuttings can be directly planted into them. Roots will grow through the walls and the seedling is planted with the surrounding pellet in place.

**Root trainers** are usually rigid containers with internal vertical ribs, which direct roots straight down to prevent spiral growth. The containers are set on frames or beds above the ground to allow air-pruning of roots as they emerge from the containers. The latest developments also encourage lateral air root pruning through vertical slits.

Seedlings grown in root trainers have more vigorous and rapid root growth than seedlings grown in polybags. Outplanting survival and, more importantly, long-term survival are much better. Plants grown in root trainer systems are often ready for planting out when they are substantially smaller than those from conventional polybags. This helps to reduce space requirements in the nursery and transport costs to the field.

type	description	cost per unit	comments
<b>polybag</b>	black or clear polyethylene; 0.3–45 L volume	US\$ 0.002–0.003 for the commonly used 0.5–1.5 L sizes	often made locally; usually used only once; can cause spiralled roots; root system can be crushed during handling.
<b>polysleeve</b>	black or clear polyethylene; 0.3–1.5 L volume, cut from an endless roll; open at both ends	as for polybag	allow air root pruning through the open bottom; substrate can fall out, therefore of limited usefulness when transporting seedlings to the field; usually used only once; root system can be crushed during handling.
<b>jiffy pots and pellets</b>	pots made from compressed peat	US\$ 0.03–0.06	roots penetrate the container easily; can only be used once as the containers are planted with the seedling; easy planting but danger of root system drying out if planted too shallowly (wick effect).
<b>root trainer</b>	rigid containers with internal vertical ribs	US\$ 0.04–0.10	big holes in bottom allow air root pruning; can be used 4–6 times; vertical ribs force roots to grow straight; some types open like a book to allow easy extraction of seedlings; require raised nursery frames; root damage during handling is negligible.

There may be some confusion in different countries concerning the term 'root trainer'. It was chosen because the internal ridges direct (i.e. 'train') roots to grow vertically downwards. Many companies produce root trainers of different types. The original container marketed was patented under the name Roottrainer®.

The classic RoottrainersR, first manufactured in Canada, have a special feature in that they consist of 'books' of four or five cells (one cell is used for each seedling) that can be opened for easy inspection and to remove seedlings for planting. Several of these books are packed into trays manufactured to fit the size of books. Bread trays or other home-made trays with a perforated

## Section 2

bottom that allows air root pruning can be improvised too. These containers are ideal for research studies as they can be opened and closed during plant growth to observe actual root development of the species or substrate tested without damaging the seedlings. Root trainers are made of rigid polyethylene and when stored open, do not require a lot of storage space. They can be used

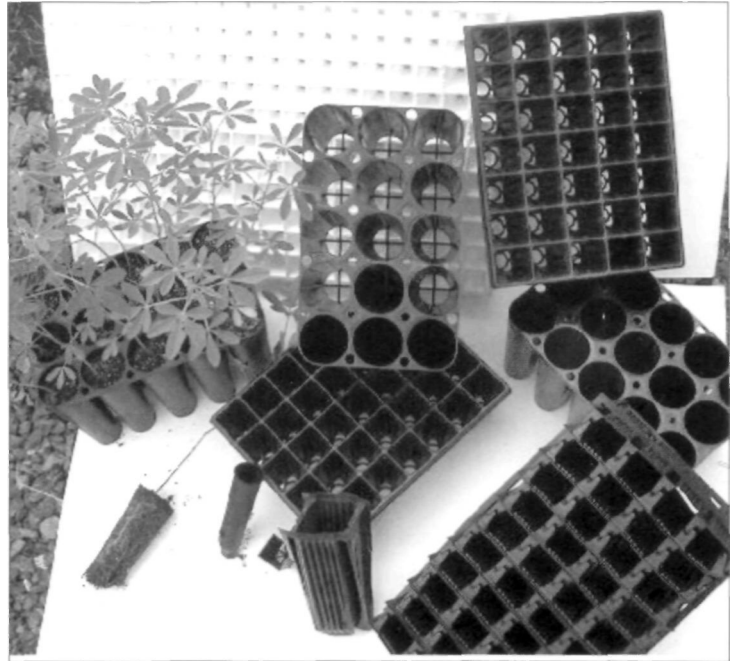

A variety of root trainer systems

two to four times before the plastic wears out from repeated opening and closing, as well as the high UV radiation in tropical countries. Current prices for root trainers (1998, excluding shipment) are US\$ 0.04-0.10 per cell including the costs for the tray.

Other manufacturers produce square or round pots within rigid trays. Cost per cell is similar to the example above; separate trays are not needed and often, the plastic material used is more rigid and durable than for root trainers. A disadvantage is that it might be more difficult to extract the seedlings from

the containers, which is a serious problem when the substrate has a large mineral (i.e. soil or sand) content. Single pots are also available which have the advantage that plants can be rearranged within a tray, for example after culling or for an experiment.

If you choose the root trainer system, you may need to adapt other nursery practices to the special requirements of the system. It is important to choose a potting substrate that is fibrous so that it does not fall through the bottom holes of the containers. Sand and soil or mixtures that contain a lot of sand or soil are not suitable. You need to construct raised frames so that the base of the root trainers is at least 30 cm above the ground to allow for air pruning. Because the root trainer cells often have a smaller volume than polybags, you may need to increase the watering schedule.

Changes in management also include the outplanting step. The 'plugs' from root trainers can be transported into the field like bare-rooted seedlings, provided there is a strong fibrous root system binding the plug. This reduces transport costs. Of course you will need to take the same precautions concerning desiccation of the plants as you do for bare-rooted seedlings:

- the seedlings have to be planted on the same day you take them out of their containers
- never let the root system dry out
- keep the seedlings in the shade at all times
- special care has to be taken to avoid crushing the root system.

**Did you know?**

Seedlings produced in a project nursery in Indonesia using root trainers and a peat-based potting substrate cost about 20% more than seedlings produced in a conventional nursery in the neighbourhood which used polybags and topsoil. But reduced transport costs to the field and better seedling survival and growth eliminated this difference completely.

Similarly, the profitability of a forestry plantation is high enough to handle a 50% increase in investment without suffering more than a 2-3% loss in income. This loss can be recovered with marginal yield increases.

**And more...**

Researchers are testing other methods of increasing fine root system development. Coating the inner surface of a container with copper hydroxide has been found to efficiently stop root growth once the roots touch the surface, and to increase the development of lateral roots. Once outplanted, the roots start growing again, thus giving the seedling a good start in the field. The commercially available product (SpinOut® from Griffin Co. - see Annex 1) can be applied to plastic containers, polybags, cloth and cement.

**Section 2**

In a research setting the products are not usually sold. However, the slightly higher cost of producing better seedlings is a good investment — and seedling cost is marginal compared with the overall expenses of a research project.

*Further reading*

- Davidson J. 1996. Off site and out of sight! How bad cultural practices are offsetting genetic gains in forestry. In: Dieters MJ, Matheson AC, Nikles DG, Harwood CE and Walker SM. (eds). Tree improvement for sustainable tropical forestry. Proceedings, Queensland Forest Research Institute Conference, Caloundra, Queensland, Australia. 288-294.
- Dunn GM, Huth JR and Lewty MJ. 1997. Coating nursery containers with copper carbonate improves root morphology of five native Australian tree species used in agroforestry systems. *Agroforestry Systems* 37: 143-155.
- Gera M, Sharma S, Bhandari AS and Srivastava RL. 1996. A trial on improved polybag seedling production system. *Indian Forester* 122(11): 992-998.
- Josiah SJ and Jones N. 1992. Root trainers in seedling production systems for tropical forestry and agroforestry. Washington, DC, USA: World Bank. Asia Technical Department. Agriculture Division. 54 pp.
- Jones N. 1993. Essentials of good planting stock. Forests and Forestry Technical Bulletin Number 2. Washington, DC, USA: World Bank/AGRNR. 7 pp.
- Landis TD, Tinus RW, McDonald SE and Barnett JP. 1990. Containers and growing media, vol. 2, The container tree nursery manual. Agriculture Handbook 674. Washington, DC, USA: US Department of Agriculture, Forest Service. 88 pp.



- Rabeendran N and Jeyasingam. 1996. The effect of pot size and mulch on planting stock of exotic and indigenous species in Sri Lanka. In: Yapa AC (ed.). Proceedings of the International Symposium on Recent Advances in Tropical Tree Seed Technology and Planting Stock Production. Muak-Lek, Saraburi, Thailand: ASEAN Forest Tree Seed Centre. 119-125.
- Struve D, Arnold M, Beeson R, Ruter J, Svenson S and Witte W. 1994. The copper connection. *American Nurseryman*. 52-56.
- Valli I. 1996. Production of high quality seedlings in central nurseries in Indonesia. In: Yapa AC (ed.). Proceedings of the International Symposium on Recent Advances in Tropical Tree Seed Technology and Planting Stock Production. Muak-Lek, Saraburi, Thailand: ASEAN Forest Tree Seed Centre. 130-135.

## Section 3: Substrates

Most nurseries use mixtures of topsoil with organic and inorganic additions. However, these don't always allow the development of a good fibrous root system. In this chapter, we discuss what makes a good substrate and describe a variety of organic and mineral substrates suitable for agroforestry nurseries in the tropics.

Good plant development depends to a large part on the growing medium used. If a plant develops a good root system in a well-balanced substrate, this does not mean that the plant is pampered and will not adapt to the harsh life outside a nursery. In fact, the opposite applies. To survive in the harsh environment of a field, often without additional watering and fertilizing, a plant needs a well-developed and strong root system. The development of a healthy root system depends not only on the genetic properties of the plant but to a large extent on the physical and chemical properties of the substrate used.

### *Physical and chemical properties*

*A substrate should:*

- be light in weight to ease transport to the planting site
- hold cuttings or seedlings firmly in place
- retain enough moisture to avoid need for frequent watering
- be porous enough for excess water to drain easily
- allow sufficient aeration of the roots
- be free from seeds, nematodes and diseases
- be able to be sterilized without changing its properties
- have enough nutrients for a healthy initial development of plants
- not have a high salinity level
- have a suitable pH
- be stable and not swell or shrink excessively or crust over in the sun.

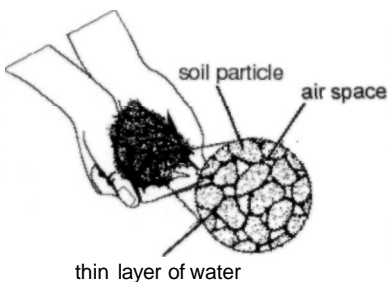

The substrate properties that influence seedling growth can be divided into physical properties (water-holding capacity, porosity, plasticity and bulk density) and chemical properties (fertility, acidity and buffer capacity).

<p><b>Physical properties</b></p>	
<p><b>water-holding capacity</b></p>	<p>A substrate that allows a large amount of water to be held without waterlogging does not need frequent irrigation. The water-holding capacity is also a function of the container used. In shallow containers the substrate has a higher water-holding capacity than in deep containers (see box on p. 32).</p>
<p><b>porosity</b></p>	<p>A good porosity is needed to allow sufficient oxygen to reach the roots to prevent rotting. All living cells, including plant roots, need oxygen for respiration and growth, and they give off carbon dioxide. To maintain adequate oxygen and carbon dioxide levels in the substrate, gas exchange with the atmosphere must be guaranteed. An oxygen content of below 12% in the substrate inhibits new root initiation; between 5 and 10% the levels are too low for established roots to grow; and at levels below 3%, roots do not function and eventually they die. Desirable total porosity values which maintain oxygen levels above 12% are around 50-80% by volume. Clay soils, which are unsuitable for seedling production, can have values of 40% or lower.</p>
<p><b>plasticity</b></p>	<p>A substrate that shrinks and cracks when drying, such as a clayey soil, damages the plants by shearing off roots.</p>
<p><b>bulk density (weight per volume)</b></p>	<p>A substrate that has a light weight is easier to transport to the field. However, containers have to be sufficiently heavy so that they do not get blown over in the wind.</p>

## Section 3

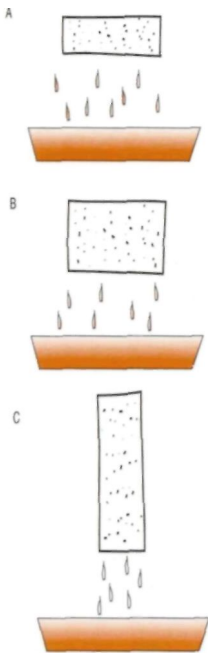
**Water-holding capacity**

Use an ordinary sponge to show how container height affects the water holding capacity: saturate the sponge and hold it flat over a tray (A). When the sponge stops dripping, turn it on its side — more water will drip out (B). When it stops dripping, stand it on end and more water will drain into the tray (C). Each time the height of the water column in the sponge increases, the amount of water it can hold decreases. In other words, deeper containers hold proportionally less water than the same amount of substrate in a shallow container. This explains why native soils, when put into a container, are often waterlogged: their depth has been reduced from metres to a few centimetres.

**Calculating water-holding capacity and porosity**

You can calculate the water-holding capacity and porosity of a substrate by the following steps:

1. With drainage holes sealed in an empty container, fill the container with water and record the volume required to fill the top of the container. This is the **container volume**.
2. Empty and dry the sealed container and fill it with dry substrate to the top.
3. Using a measured volume of water, irrigate the substrate in the container very slowly until it is saturated with water. This might take several hours; you must be sure you don't trap air in the substrate. The saturation point is reached when water stays visible on the surface of the medium. Note how much water you have used. The volume of water needed to reach this point is called the **total pore volume**.
4. Remove the seal from the drainage holes and catch the water as it runs out. Wait several hours until all water has dripped out. Record the volume collected - this is the **aeration pore volume**.
5. Calculate total porosity, aeration porosity and water-holding porosity using the following equations:

$$\text{Total porosity (\%)} = \frac{\text{total pore volume}}{\text{container volume}} * 100$$

$$\text{Aeration porosity (\%)} = \frac{\text{aeration pore volume}}{\text{container volume}} * 100$$

$$\text{Water-holding porosity (\%)} = \text{total porosity} - \text{aeration porosity.}$$

A good growing medium for most agroforestry trees has a total porosity of above 50% of which 30-50% is aeration porosity.

**Chemical properties****fertility**

As soon as a seedling has used up the nutrients provided by its cotyledons (about two weeks after germination), it needs nutrients from the growth medium. The basic nutrients, of which plants require relatively large amounts, are nitrogen (N), phosphorus (P) and potassium (K). Plants also need very small amounts of other nutrients ('micronutrients') and deficiencies in micronutrients can occur in the nursery. The micronutrients that agroforestry trees are most often lacking are iron (yellow, 'chlorotic' leaves), especially in soils with a high pH or those derived from limestone, and boron (shoot tip dries out), especially in soils from igneous rocks.

**acidity**

The right substrate pH is very important for healthy plant development. The reason for this is that nutrients become available for plants at different pH levels. The optimum is around 5.5 for organic soils and around 6.5 for mineral soils. Most plants grow best in a medium with near-neutral pH (5.5-6.5), although some plants are particularly tolerant of acidity (for example *Inga edulis*, *Casuarina junghuhniana*) or alkalinity (for example *Prosopis chilensis*, *Tecoma stans*).

**cation exchange capacity**

The cation exchange capacity (CEC) is the ability of a material to adsorb positively charged ions ('cations'). It is one of the most important factors affecting the fertility of a growth substrate. The main cations involved in plant nutrition are calcium, magnesium, potassium and ammonium, listed in order of decreasing retention in the substrate. Many micronutrients are also adsorbed, such as iron, manganese, zinc and copper. These nutrients are stored on growth medium particles until they are taken up by the root system.

In practical terms, the CEC indicates the fertilizer storage capacity of the substrate and indicates how frequently fertilizer needs to be applied. Some soils contain high amounts of clays which adsorb cations so strongly that they become unavailable for plant nutrition (mineral 'fixation'). These soils are unsuitable for nursery purposes.

Although the CEC of some soil-less substrates is very high, anions get washed out easily and need to be replenished frequently. This is particularly important for phosphorus and for nitrogen in the form of nitrate. Mixing a slow-release P-fertilizer, such as rock phosphate, into the substrate before planting can help alleviate this problem.

## Section 3

**Bulk densities and CEC for various growth substrates**

CEC is traditionally measured on a weight basis for field soils, but CEC per volume is more meaningful for container growth media, because of the relatively low bulk density of most media and the small volumes of the containers. CEC values for some typical growth medium components are compared below. Vermiculite and peat moss have the highest CEC values, whereas materials such as perlite and sand have very low CEC values.

substrate	approximate dry bulk density (g/L)	CEC meq/L
perlite	ca 100	1.5–3.5
sand	1400–1700	45–105
pine/fir bark	200–300	ca 100
vermiculite	ca 120	88–165
peat	ca 110	110–198

*Soil and soil-less media*

All nursery managers have their own favourite growth substrate. These vary depending on availability, but in developing countries they are mainly soil from agricultural or forest areas, sometimes mixed with sand and/or manure.

Forest soil is often a main component of potting mixtures. Soil is usually a mixture of mineral components from weathered parent rock and of organic components from decomposed litter. Whereas the topsoil (the top 10-20 cm) can be very rich in nutrients, subsoil from deeper layers is often very poor and depleted. When using soil as a potting substrate it is advisable to use only forest topsoil. Topsoil usually has a good CEC. Its pH is largely determined by the parent rock and the plant composition (soil under conifers tends to be more acidic). However, nurseries requiring large volumes of substrate need to consider the damage soil mining does to the forest floor.

As a rule of thumb when soil is to be part of the growing medium, use the following mixtures (topsoil: fine gravel: well-decomposed organic matter such as manure or compost):

for heavy (clayey) soils 1:2:2

for medium (loamy) soils 1:1:1

for light (sandy) soils 1:0:1

A common problem in the nursery is the variability of the substrate used. If forest soil is used, once a good source is depleted, soil is obtained from a neighbouring plot, usually without paying attention to changes in soil properties. If organic substrates are used, the source material for these may vary in quality, influencing the quality of the final potting mixture. When using soil it is advisable to have a chemical analysis done on each batch so that supplementary fertilizer can be applied if necessary. In fact, most large container nurseries never include soil in their substrate.

As an alternative to native soil, organic and inorganic soil-less substrates have been receiving increased attention in tropical nurseries. There are two main reasons for this: firstly, the soil-less materials have, in appropriate mixtures, optimal physical and chemical properties, and secondly, they do not contain weed seeds, fungal spores or insects, or they can be heat sterilized without losing their properties, whereas soil changes its physical and chemical properties under high temperatures — for example, toxic levels of manganese can occur.

The two major groups and components of soil-less media are:

- **inorganic:** for example, gravel, sand, vermiculite, perlite, tuff and pumice, polystyrene.
- **organic:** for example, peat, charcoal, softwood and hardwood barks, compost, rice hulls, sawdust and other organic waste products.

The choice for substrate components will depend on the location of the nursery, the resources available and plant requirements. For example, vermiculite is mined in South Africa and Kenya and is therefore comparably cheap in these locations, and peat is found in large quantities in Kalimantan, so it is a major ingredient of soil-less media in Indonesian nurseries. In many countries, bark is available as a by-product of sawmills and can be obtained cheaply.



## Section 3

***Inorganic components***

Inorganic components improve the physical structure of a substrate by increasing the aeration pore space and the drainage properties. Many inorganic materials have a low CEC and provide a chemically inert base for the substrate. Heavy materials, such as gravel, can be used to improve the stability of containers.

**Inorganic components****sand and gravel**

Sand is a common substrate for germinating seeds. Sieve and wash all sand to remove fine silt particles that lead to crusting of the surface. You will get best results with particle sizes between 0.5-1 mm for germinating seeds and 1-2 mm for rooting cuttings. Sand that comes from a seaside beach may contain high levels of salt that need to be washed out before use. Fine gravel (5 mm) has been used successfully in rooting cuttings and as an addition to potting mixtures. It needs to be thoroughly washed to remove soil and sand particles. Both sand and gravel are heavy (bulk densities 1000-1700 g/L) and make transport of seedlings to the field difficult. Sand, especially fine sand, must never be used as an addition to potting substrates, since it clogs up pores.

**vermiculite**

Vermiculite is a hydrated magnesium-aluminium-iron silicate; there are extensive deposits in the USA and South Africa. Its mineral structure is layered, like mica, and it expands when heated above 1000°C. After processing, vermiculite has a very low bulk density (ca 120 g/L). It is insoluble in water but can absorb about 5 times its own weight. It has a neutral pH and a high CEC and thus can hold nutrients in reserve. Horticultural vermiculite is graded to three sizes: coarse (2-3 mm), medium (1-2 mm) and fine (0.75-1 mm). The coarse grade is used most in growing substrates, the medium and fine grades are used in seed germination. The structure of vermiculite is fragile and once compressed the particles cannot be expanded. It is therefore important that vermiculite is not pressed during handling or mixed with large quantities of heavy material, such as sand. Use only horticultural vermiculite, because vermiculite from packing materials is often coated with water repelling chemicals.

<p><b>perlite</b></p>	<p>Perlite is a siliceous material of volcanic origin, mined from lava flows. The crude ore is crushed and heated to about 760°C, causing the enclosed water to vaporize and expand the particles like a sponge. It is very light (80-100g/L), can hold 3-4 times its own weight in water and has a near neutral pH but a very low CEC, and it contains no mineral nutrients. It is most useful to increase aeration in a mix and it is, in combination with peat moss, a very popular substrate for cuttings in the USA.</p>
<p><b>tuff (pumice)</b></p>	<p>Tuff is produced from ash and rock fragments ejected during volcanic eruptions. Some particles melt together in the heat. The material is very porous and consists of mostly silicon dioxide and aluminium oxide with small amounts of iron, calcium, magnesium and sodium. After mining, it is screened to different sizes but is not heat treated. It increases aeration and drainage in a propagation mix.</p>
<p><b>polystyrene</b></p>	<p>Expanded polystyrene flakes and other synthetic plastic aggregates are often added to improve drainage and aeration, and to decrease the bulk density of the substrate. They are inert (do not add nutrients), do not decay and do not absorb water.</p>

### *Organic components*

The organic components improve the physical structure of the substrate by reducing weight and increasing its water-holding properties. They are also resilient to compaction. Organic matter has a high CEC and can store nutrients until needed by the plants. Some organic materials, such as compost, can contain considerable amounts of nutrients. Peat is the most popular organic component, but because of the destruction of valuable biotopes for the harvest of peat, alternative materials with similar physical and chemical properties are sought.

## Section 3

**Organic components****peat**

Peat is plant material that has decomposed under partial exclusion of oxygen. These anaerobic conditions slow down bacterial and chemical decomposition and often peat is many thousand years old. Tropical peat originates from younger deposits with varying properties. Peat from different sources varies greatly in the vegetation from which it originated, the state of decomposition and mineral content. All peats have good water-holding capacity, high CEC, low level of nutrients and low pH (around 3-4.5). The most common peat is sphagnum peat, a slightly decomposed peat from *Sphagnum* mosses. It has a high water holding capacity of 15-30 times its dry weight and contains small amounts of nitrogen (0.6-1.4%). Its dry bulk density is around 110 g/L. This particular material originates mainly in Canada, Ireland and Germany. In tropical countries other less decomposed peats can be substituted for it.

**charcoal**

Charcoal dust or small pieces help to improve the CEC of a substrate. Charcoal is readily available everywhere.

**shredded bark**

Softwood or hardwood bark are good alternatives to peat moss with much the same properties. Bark is a cheap by-product of many sawmills. It can be used from softwood (cedar, pine, fir) or hardwood species; the bark of tree ferns is also recommended. There is only limited information about the suitability of tropical tree species. Bark should be hammer milled (shredded) through a 2-3 cm screen and then composted for 4-6 months because fresh bark can contain tannins, phenols, resins or terpenes which are toxic to plants unless they are broken down. The higher temperatures of composting also help reduce insect and pathogen levels. When bark is not completely composted, plants grown in this medium may suffer from nitrogen deficiency because the composting bacteria need nitrogen to break down the organic matter. Please note that in areas with severe shortages of firewood, bark might be used for this purpose by the population, and the nursery should find alternative materials so that their operations do not compete for this scarce resource.

<p><b>compost</b></p>	<p>Composting is the physical and chemical breakdown of materials that liberates nutrients available to plants. Micro-organisms (fungi and bacteria) digest the material during decomposition. Compost from green material generally has a high nutrient level and a good CEC. Producing a consistently good compost takes practice and it may be worthwhile to conduct studies to learn how different species react to the addition of compost to their potting medium, and to make adjustments if necessary. Any organic material can be composted; a mixture of materials is best (see box). Compost is a very important ingredient in nurseries on coral atolls in the Pacific.</p>
<p><b>other materials</b></p>	<p>Coconut husks, rice hulls, sugar cane bagasse, coffee shells, old sawdust and other waste materials can be used similarly to the materials listed above. New materials will doubtless be found through continuous research. Most soil-less substrates can be used alone or added to soil to improve its properties.</p>

### *Producing compost*

Each nursery site can have unique materials for composting because all that is needed is a very large supply of low cost vegetative material (green matter shrinks to only a fifth of its original volume during the composting process). For compost production the only machine needed is a straw cutter, cheap and available in any agricultural community. This is needed because the vegetative material must be chopped to fairly uniform small sizes. The compost heaps will be above the ground and can be either in the open during the dry season or under shelter from rain.

Good compost requires careful management of the micro-organisms which digest the vegetative material — their diet is best fed with vegetative material having a C:N ratio of 25-30 (see examples on p. 40). They also require moisture and oxygen. Heaps should not be wet — the best moisture level is 55%. Initially there will be adequate oxygen but as the micro-organisms function

## Section 3

To make good compost you need material with a C:N ratio of 25-30. Keep the heap at 55% moisture and at a temperature of about 60°C.

this will be used up in the process of digestion. In addition, the temperature of the heap will quickly increase due to the activity of the micro-organisms. Two types of micro-organisms are present in the compost-making process: (1) the 'normal' type, which occurs in abundance during normal decomposition; (2) 'thermophilic' (temperature loving) micro-organisms. The normal micro-organisms quickly raise the temperature of the heap to 40°C. At this temperature they die, leaving the thermophilic micro-organisms to continue digestion. These heat-loving organisms operate very quickly, raising the temperature considerably and using up oxygen rapidly. They die if the temperature exceeds 65°C, the oxygen supply fails or the heap becomes either too dry or too wet.

#### C:N values for some materials

Material	C:N ratio
cow manure	18
horse manure	25
young hay clippings	12
cut straw	48
rotted sawdust	208-210
raw sawdust	400-511
sugarcane trash	50
fruit wastes	35
cabbages	12
tobacco	15
potato tops	25
pine wood	723

Nitrogen requirements for composting sawdust and bark:

sawdust: 0.5-1.1 kg N/m<sup>3</sup>

bark: 0.2-1.9 kg N/m<sup>3</sup>

Thus the art of making good compost quickly lies with the care of the thermophilic micro-organisms. Nursery managers must monitor the C:N ratio, chop up vegetable matter into small pieces of similar sizes, ensuring adequate but not excessive moisture, supply enough oxygen and ensure that the temperature does not exceed 60°C. Temperature and oxygen control are linked because, by lifting and turning the heap, temperature is reduced and oxygen is supplied. The compost is ready when it looks brown — it should have the consistency of coarsely ground coffee. You can determine whether the compost

is ready by placing two handfuls of the material into a plastic bag and leave the bag sealed for 24 hours in a dark place. If you open it and no odour or heat is noticeable, the compost is ready. The ready compost can then be removed from the bed and stored for another four months to mature. If you put a plastic sheet with fine holes over the heap this will allow the compost to breathe but will prevent weed seeds from entering.

### *Suggested mixes*

For any species, research is needed to find out the optimal substrate. When mixing, it is important that all components are finely ground and sieved through a 5 mm sieve to remove excessively large particles. When mixing by hand, the components are placed in layers on a heap and then turned thoroughly with a shovel. Alternatively, a cement mixer or a drum can be used. When peat or shredded bark is part of the mixture, it is very important that the material is wetted **before** mixing. Although the literature often recommends the addition of wetting agents, this is not necessary when special attention is given to thorough wetting of the mixture during the mixing process.

#### **Calculating the amount of substrate needed**

Before mixing, you need to know roughly how much substrate you will need. Start with the container volume and the number of containers to fill. To calculate volume you can seal the drainage holes of the container and fill it with water from a measuring cylinder, noting how much water you filled. Or you can calculate it by measuring the height and diameter of the container, assuming it is cylindrical:

$$\text{volume} = \pi r^2 h$$

(height x  $\frac{1}{2}$  diameter squared x 3.1416).

Once you know the volume of the container, multiply this by the number of containers needed. For example: volume = 500 ml; 10 000 seedlings needed. Total volume needed is 500 x 10 000 = 5 000 000 ml or 5000 litres or 5 m<sup>3</sup>. Then calculate the amount of each component needed.

## Section 3

**Suggested mixes****germination**

Often fine, washed quartz sand (0.5-1 mm) is adequate. However, it needs constant monitoring as sand dries out easily. If easily available, fine grade vermiculite, vermiculite mixed with peat or hammer-milled and composted bark, or composted coconut husks are good alternatives.

**cuttings**

Depending on the species' moisture requirements, fine, washed quartz sand, sand mixed with fine gravel at various ratios or composted sawdust, bark or vermiculite is used. When starting with a new species, the best bet is usually sand (2 mm fraction), and research at a later stage will determine if any of the other media are better.

Sterile media without nutrients are usually recommended in the rooting stage, and once rooted the cuttings can be transferred to other substrates with fertilizers. Alternatively, cuttings can also be rooted in substrates treated with fertilizers, which will avoid the transplanting step. However, in substrates containing fertilizer, infection of the cuttings with bacterial moulds and algae growth are more prevalent. It is very important that cuttings should not be set in soil or media containing soil because these substrates usually do not have the required high porosity for sufficient gas exchange, which can lead to rotting of the cuttings. Exceptions are stakes of easy-to-root species (such as *Gliricidia sepium*) that can be directly struck at the final field location.

**container seedling production**

There are probably as many recommended potting mixtures as there are nurseries. Global recommendations do not exist. Usually the mixtures contain vermiculite, peat or hammer-milled bark in various proportions, and fertilizers. For tropical countries alternative substrates, such as coconut husks, rice hulls and compost have given good results with various species. Although the use of many different mixtures in a nursery is not feasible, simple screening experiments testing three or four mixtures can easily be carried out for each species.

Although many soil-less media do not contain nutrients, they are very popular in commercial plant propagation. This is mainly because the fertilizer schedule for the plants can be individually tailored to each species and development stage. Compost, on the other hand, is popular because it is usually so rich in nutrients that it can be used as a substrate which at the same time has good fertilizer properties.

### *Further reading*

- Bilderback TE. 1982. Container soils and soilless media. Nursery Crops Production Manual no. 9. Raleigh, USA: North Carolina Agricultural Extension Service. 12 pp.
- Hartmann HT, Kester DE, Davies FT and Geneve RL. 1997. Plant propagation. Principles and practices. Sixth edition. London, UK: Prentice Hall International. 770 pp.
- Hossain MK and Kamaluddin M. 1996. Potting media effects on *Albizia procera* growth. Forest, Farm, and Community Tree Research Reports. 1: 51-54.
- Kasica AF and Good GL (eds). 1997. Something to grow on. Cornell Cooperative Extension/Dept of Floriculture and Ornamental Horticulture. Ithaca, USA: Cornell University. URL: <<http://www.cals.cornell.edu/dept/flori/growon/about.html>>
- Kijkar S. 1991. Coconut husk as a potting medium. Handbook. Muak-Lek, Saraburi, Thailand: ASEAN-Canada Forest Tree Seed Centre Project. 14 pp.
- Landis TD, Tinus RW, McDonald SE and Barnett JP. 1989. The biological component: nursery pests and mycorrhizae. vol. 5, The container tree nursery manual. Agriculture Handbook 674. Washington, DC, USA: US Department of Agriculture, Forest Service. 171 pp.
- Landis TD, Tinus RW, McDonald SE and Barnett JP. 1990. Containers and growing media, vol. 2, The container tree nursery manual. Agriculture Handbook 674. Washington, DC, USA: US Department of Agriculture, Forest Service. 88 pp.
- Macdonald B. 1986. Practical woody plant propagation for nursery growers. Portland, Oregon, USA: Timber Press. 669 pp.
- Mengel K. 1984. Ernährung und Stoffwechsel der Pflanze [Nutrition and metabolism of plants]. 6<sup>th</sup> edition. Stuttgart, Germany: Gustav Fischer Verlag.



## Section 3

- Miller JH and Jones N. 1995. Organic and compost-based growing media for tree seedling nurseries. World Bank Technical Paper no. 264. Forestry Series. Washington, DC, USA: World Bank, 75 pp.
- Rabeendran N and Jeyasingam. 1996. The effect of pot size and mulch on planting stock of exotic and indigenous species in Sri Lanka. In: Yapa AC (ed.). Proceedings of the International Symposium on Recent Advances in Tropical Tree Seed Technology and Planting Stock Production. Muak-Lek, Saraburi, Thailand: ASEAN Forest Tree Seed Centre. 119-125.
- Schauer T. 1996. Methyl bromide: an international inconsistency? In <http://www.brobeck.com/docs/methyl.htm>. Brobeck, Phleger and Harrison environmental law practice.
- Smith FW, Vanden Berg PJ, Gonzalez A, Andrew CS and Pieters WHJ. 1992. Foliar symptoms of nutrient disorders in the tropical shrub legume *Leucaena leucocephala*. Division of Tropical Crops and Pastures Technical Paper no. 32. Canberra, Australia: CSIRO. 14 pp.

## Section 4: Fertilizers

When using soil or soil-based media, you might not need to fertilize the seedlings immediately because the substrate has residual fertility. However, with most soil-less substrates and during the production phase, seedlings need the addition of balanced nutrients. In this chapter, we describe the essential plant nutrients and discuss various organic and inorganic fertilizers.

Fertilizers provide plants with the nutrients necessary for healthy growth. Apart from the macronutrients N, P, K, Ca, Mg, and S there is a known suite of micronutrients (Fe, Mn, B, Cu, Cl, Zn and Mo) that play important roles in the plant's metabolism.

When you use soil- or compost-based media, the substrate might contain enough nutrients for good plant growth. However, it is advisable to analyse the substrate for available plant nutrients regularly. If laboratory facilities are not available locally, institutions such as ICRAF offer this service for a fee<sup>1</sup>. Although the optimal ranges are not known for most agroforestry tree species, figures for some general groups are available and can be used as guidelines. You can also monitor the plants themselves for symptoms of deficiency.

When using soil-less substrates, apart from compost, it becomes very important to fertilize seedlings.

When using soil-less substrates, apart from compost, it becomes very important to fertilize seedlings. Most soil-less media contain few or no nutrients and, with a few exceptions, their CEC is very low. Seedlings need nutrients from the growth substrate after the nutrients provided in the cotyledons become depleted. This is usually within the first couple of weeks after emergence — from then on, plants grown in a soil-less substrate need to be fertilized regularly and frequently.

Fertilizer can be applied in various forms as either organic or inorganic fertilizer.

<sup>1</sup> For information contact the Laboratory Manager, ICRAF Plant and Soil Laboratories, PO Box 30677, Nairobi, Kenya. Tel +254 2521450, fax +254 2521001, email: [icraf@cgiar.org](mailto:icraf@cgiar.org).

Section 4

<b>Macronutrients</b>		
<b>name (symbol)</b>	<b>function</b>	<b>deficiency symptoms (very general)</b>
<b>nitrogen (N)</b>	Important component of amino acids and proteins.	Old leaves turn yellow, plant growth retarded, small leaves. Be careful: too much nitrogen leads to overgrown plants which are highly susceptible to diseases.
<b>phosphorus(P)</b>	Provides energy (ATP). Helps in transport of assimilates during photosynthesis. Important functions in fruit ripening.	Small plants with erect growth habit; thin stems, slow growth. Leaves appear dirty grey-green, sometimes red.
<b>potassium (K)</b>	Important in maintaining cell turgor, phloem transport, cell growth and cell wall development (K deficiency leads to susceptibility to pests because cell walls are weakened).	Older leaves show first chlorotic, later necrotic borders. Younger leaves remain small.
<b>calcium (Ca)</b>	Stabilizes cell membranes and cell walls, interacts with plant hormones. Ca is extremely immobile and can only be taken up through young, un lignified roots.	Deficiency is often only visible in retarded growth.
<b>magnesium (Mg)</b>	Component of chlorophyll-photosynthesis is hindered when deficient. Binds ATP to enzymes. important for protein synthesis.	Old leaves chlorotic from middle or between veins, rarely necrotic. Leaves orange-yellow, drop prematurely.
<b>sulphur (S)</b>	Component of etheric oils, vitamin B, vitamin H, amino acids, and has important functions in protein synthesis.	Similar to N-deficiency but symptoms show first on young leaves.

<b>Micronutrients</b>		
<b>name (symbol)</b>	<b>function</b>	<b>deficiency symptoms (very general)</b>
<b>iron (Fe)</b>	Component of chloroplasts. Part of the redox system in the electron transport during assimilation, and important for RNA synthesis.	Young leaves turn yellow to white.
<b>manganese (Mn)</b>	Important for enzyme activation, photolysis. When deficient, protein synthesis and carbohydrate formation are hindered.	Youngest leaves show chlorotic spots, later they grow into necrotic areas parallel to the veins.
<b>copper (Cu)</b>	Found in chloroplasts. Important for carbohydrate synthesis and protein synthesis.	Youngest leaves are chlorotic or necrotic, fruit set is insufficient.
<b>zinc (Zn)</b>	Has enzyme activating function, e.g. starch synthetase; is found in chloroplasts.	Small leaves and short internodes; thin shoots.
<b>molybdenum (Mo)</b>	Important component of enzymes, specifically nitrate reductase and nitrogenase. Essential element for all nitrogen-fixing plants.	Old leaves develop necrotic borders, often the symptoms are caused by secondary N-deficiency.
<b>boron (B)</b>	Found in cell walls, important for transport of assimilates and cell growth. If deficient, shoot tip dries.	Youngest leaves are deformed, thick, dark green to greyish. Root system development is hindered.
<b>chlorine (Cl)</b>	Important in maintaining cell turgor, increases sugar content in fruits.	Deficiency symptoms occur only in halophytes (salt-loving plants), mainly as loss in turgor.

*Organic fertilizers*

Compost from vegetative matter or animal manure has been discussed in the previous section as an organic component of potting substrates. Due to its generally high nutrient content it is also a valuable fertilizer and helps improve the physical and chemical properties of soil-based mixtures.

## Section 4

**Organic fertilizers****animal manure**

Manure differs in its nutrient composition depending on the animal source (see page 49) and the season. This source will only have consistency if it is collected from reputable commercial farms where animals are fed a controlled and constant diet. In all cases where animal manure is used, include it in a composting programme. Leave manure to rot for 6-10 weeks to reduce the risk of 'burning' plants due to high nitrogen concentrations. This is particularly important for chicken or other bird manure in which nitrogen levels are very high. You can test whether manure is ready by using the same method you can use for compost: put two handfuls of the moist material into a small plastic bag and leave it sealed for 24 hours in a dark place. If it heats up considerably and there is a strong smell of ammonia when you open the bag, it is not ready to use yet. Apart from nutrients, manure adds a high amount of organic matter to a potting substrate and improves its physical conditions. Analytical monitoring of the nutrient composition of manure is essential for uniform plant production. Weeds and insects can easily be introduced into the nursery with manure unless it is properly composted. Manure can also be suspended in water and used for irrigation. This practice utilizes mainly the nitrogen component in manure.

**composted green matter**

Like manure, compost properties vary with its components, the composting duration and the temperatures maintained during composting. If possible, do a chemical analysis of each batch before you use it. It takes considerable time and experience to produce compost of a uniform quality from batch to batch (see page 39).

**animal waste**

These include hoof and horn meal, bone meal, fish meal and chicken feathers. They are fertilizers which slowly release nutrients into the substrate. Hoof and horn meal and feathers are rich in nitrogen; bone and fish meals rich in phosphorus. These materials also have a positive influence on the porosity of the substrate.

Tentative soil fertility thresholds for pines and eucalypts (in ppm)				
element	pines		eucalypts	
			min	max
P	25	200	25	200
K	8		10	
Ca	20		40	
Mg	3		3.5	
Mn	5	200	5	200
Cu	1	20	1	20
Zn	1.5	30	1.5	30
B	0.3	5	0.5	5

Approximate nutrient contents of fresh manure of various farm animals			
	nitrogen (%)	phosphoric acid (%)	potassium (%)
cow	0.35	0.2	0.1-0.5
goat/sheep	0.5-0.8	0.2-0.6	0.3-0.7
Plg	0.55	0.4-0.75	0.1-0.5
chicken	1.7	1.6	0.6-1
horse	0.3-0.6	0.3	0.5

### *Inorganic fertilizers*

#### *Granular inorganic fertilizers*

Inorganic fertilizers are divided into single fertilizers, compound fertilizers and full fertilizers (see page 50). They can be applied by broadcasting or by mixing with the irrigation water ('fertigation'). Fertilizers are commonly known by the contents of the main nutrients N, P and K. The numbers on the

## Section 4

bags show the content of these components. For example 20-10-20 fertilizer contains 20% N, 10% P, usually in the form of  $P_2O_5$ , and 20% K, usually in the form of  $K_2O^3$ . Urea, a single fertilizer containing only nitrogen is labelled 46-0-0, indicating that it has 46% nitrogen, but neither phosphorus nor potassium. The remaining parts are made up of the non-N ( $P_2O_5$ ,  $K_2O$ ) parts of the molecules and inert carrier materials.

When soil-less growth media are used, fertilizing with full fertilizers which also include micronutrients is necessary. Especially under tropical conditions and with irrigation, plants can grow actively throughout the year. This means that they need nutrients continuously and fertilizer needs to be applied at frequent intervals (weekly or fortnightly). Fertilizer should not be applied during germination, because it leads to increased bacterial and fungal infections. As seedlings develop, fertilizer schedules have to be adjusted. Some people use a mixture of fast- and slow-release fertilizers so that seedlings are planted into the field with a fertilizer reservoir.

<b>Types and examples of granular fertilizers</b>	
<b>single fertilizers</b>	contain only one nutrient: urea (N) superphosphate (P) rock phosphate (P)
<b>compound fertilizers</b>	contain two nutrients: DAP (N,P) CAN (N,Ca)
<b>full fertilizers</b>	Contain all three main nutrients: NPK 20-20-20 (N,P,K) NPK 17-17-10 (N,P,K)  Also available with some or all necessary micronutrients: NPK 12-12-17-2 (N,P,K + Mn) Bayfolan (N,P,K + micronutrients)

<sup>2</sup> to convert % $P_2O_5$  to %P multiply with 0.44

<sup>3</sup> to convert % $K_2O$  to %K multiply with 0.86

**How to calculate the right fertilizer concentration**

Usually, fertilizer requirements are given in ppm (parts per million), or mg/kg or L. If you use a 19-19-19 fertilizer, a 50-80 ppm solution is recommended for frequent use. Calculate the correct amount like this:

- In a 19% N (or P<sub>2</sub>O<sub>6</sub>, or K<sub>2</sub>O) fertilizer, 100 g fertilizer contains 19 g or 19 000 mg N (or P<sub>2</sub>O<sub>6</sub>, or K<sub>2</sub>O) a solution of 50 ppm is wanted (50 mg N in 1 L)
- $100\text{g} \times 50 \text{ mg}/19\ 000 \text{ mg} = 0.263 \text{ g}$  or 263 mg.

For each litre of fertilizer solution, dissolve 263 mg of granular 19-19-19 fertilizer.

*Controlled-release fertilizers*

Controlled-release fertilizers provide an attractive alternative to granular fertilizers. These are fertilizer 'cocktails' that slowly release nutrients to the substrate. The release depends on water availability or soil temperature. Controlled-release fertilizers are more expensive than the more common water soluble fertilizers, but they have several advantages:

- the danger of over-fertilizing is reduced as the release of fertilizers occurs gradually
- fertilizing is necessary only occasionally, sometimes only once in a season
- a balanced fertilizer mixture is provided at all times as the plants get what they need at different growth stages nutrients do not leach from the substrate so the plants receive all the nutrients applied.

Controlled-release fertilizers provide an attractive alternative to granular fertilizers.

Experimenting with controlled-release fertilizers will help you determine the best application rates and times.

*The principle of controlled-release fertilizers*

In products using the Osmocote<sup>R</sup> technology, resins based on natural organic oils, such as soybean or linseed oil, are used to coat fertilizers. Different thicknesses of resin coating are applied to the base fertilizer to achieve different release periods. Water enters the granule and dissolves the nutrients and they



## Section 4

pass through the coating at a rate controlled by the soil temperature. As temperatures fluctuate the rate of nutrient release changes, matching plant demand as growth rates rise and fall in correlation with these changes. The resin coating remains intact throughout the life of the product. When all nutrients are expended the coating dissolves. There are products for specific markets, such as ornamentals, vegetables and nursery production. They last from 3-4 months to 16-18 months depending on the soil temperature. Estimated lifetime is based on an average temperature of 21°C; release rates change by about 25% for every 5°C. In a tropical environment with an average soil temperature of 28°C, a product labelled four months would last roughly three months.

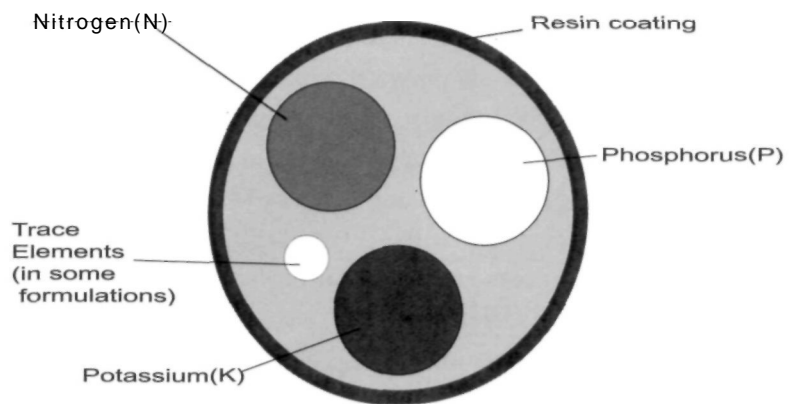

<b>Examples of controlled-release fertilizers</b>				
<b>fertilizer</b>	<b>analysis (N-P-K)</b>	<b>release mechanism</b>	<b>length of time it lasts at 21°C</b>	<b>N source</b>
<b>Lesco</b>	20-6-12	temperature	4–6 months	sulphur coated urea and ammonium nitrate
<b>MagAmp</b>	7-40-6 + 12Mg	moisture	4–12 months	magnesium ammonium phosphate
<b>Osmocote</b>	18-6-12 14-14-14 13-13-13 19-6-12 17-7-12	temperature, coating thickness; no change with media moisture	8–9 months 3–4 months 8–9 months 3–4 months 12–14 months	ammonium nitrate and ammonium phosphate
<b>Sulphur coated urea</b>	36-0-0 + 17S	temperature, media moisture, coating thickness	up to 6 months, approx. 1% per day	sulphur coated urea
<b>Ureaform</b>	38-0-0	increases with temperature, maximum at pH 6.1 and 50% water saturation; bacterial action	60% in 6 months	urea-formaldehyde

Most of these products are available on the international market, sometimes under a different name. For example, "Season Long" 20-10-20 is a product of Phostrogen that acts using the osmocote technology.

*Further reading*

- Cabrera RI. 1997. Comparative evaluation of nitrogen release patterns from controlled-release fertilizers by nitrogen leaching analysis. *HortSci.* 32(4): 669-673.
- Davey CB. (not dated). Tentative soil fertility thresholds for acceptable growth of pines and eucalypts in nurseries and seed orchards. Raleigh, USA: North Carolina State University.
- Dell B, Malajczuk N and Grove TS. 1995. Nutrient disorders in plantation eucalyptus. *ACIAR Monograph 31*. Canberra, Australia: ACIAR. 110 pp.
- Landis TD, Tinus RW, McDonald SE and Barnett JP. 1989. Seedling nutrition and irrigation, vol. 4, The container tree nursery manual. *Agriculture Handbook 674*. Washington, DC, USA: US Department of Agriculture, Forest Service. 119 pp.
- Mengel K. 1984. Ernährung and Stoffwechsel der Pflanze [Nutrition and metabolism of plants]. 6<sup>th</sup> edition. Stuttgart, Germany: Gustav Fischer Verlag.
- Miller JH and Jones N. 1995. Organic and compost-based growing media for tree seedling nurseries. *World Bank Technical Paper no. 264*. Forestry Series. Washington, DC, USA: World Bank, 75 pp.
- Smith FW and Vanden Berg PJ. 1992. Foliar symptoms of nutrient disorders in the tropical shrub legume *Calliandra calothyrsus*. *Division of Tropical Crops and Pastures Technical Paper no. 31*. Canberra, Australia: CSIRO. 14 pp.
- Smith FW and Vanden Berg PJ. 1992. Foliar symptoms of nutrient disorders in *Cassia rotundifolia*. *Division of Tropical Crops and Pastures Technical Paper no. 33*. Canberra, Australia: CSIRO. 14 pp.
- Smith FW, Vanden Berg PJ, Gonzalez A, Andrew CS and Pieters WHJ. 1992. Foliar symptoms of nutrient disorders in the tropical shrub legume *Leucaena leucocephala*. *Division of Tropical Crops and Pastures Technical Paper no. 32*. Canberra, Australia: CSIRO. 14pp. [www. scottspro.co.uk](http://www.scottspro.co.uk) on Osmocote products.

## Section 5:

# Nursery and plant hygiene

If you do not control pathogens and pests during propagation, your plants will be inferior, and field planting might be delayed. In this section we introduce ecologically sound concepts and ideas for improving the general level of hygiene in your nursery.

Healthy plants are the goal of every nursery manager. This is not restricted to research nurseries but applies to nurseries of all sizes and levels of sophistication. Nursery hygiene does not necessarily mean using expensive or toxic chemicals — you can achieve a healthy nursery with ecologically sound management.

Traditionally, there have been two basic approaches to nursery health: **preventive actions**, which include balanced fertilizers, use of resistant species or cultivars, timely hardening of plants, cleanliness in the whole nursery, and training of staff, and **curative actions**, which include the use of pesticides,

Factors that influence plant health	
<b>abiotic ('non-biological')</b>	<ul style="list-style-type: none"> <li>- excessively high or low temperatures</li> <li>- drought or waterlogging</li> <li>- injury due to chemicals</li> <li>- physical damage, for example shearing off roots</li> </ul>
<b>biotic (biological)</b>	all biological organisms (bacteria, viruses, viroids, phytoplasmas, fungi, insects, mites, nematodes, weeds, parasitic plants, birds and mammals) that interfere with plant production

Section 5

There are two approaches to nursery health. preventive actions and curative actions.

heat, biological control or physical measures (e.g. cutting out of diseased parts). From these two approaches, **integrated pest management** has evolved, combining 'preventive' measures with 'curative' methods, and using chemical, biological and cultural control. It is neither practical nor wholly desirable to attempt total elimination of pests — many beneficial organisms are destroyed in such efforts, and a lack of beneficial organisms can lead to an explosive recolonization of the nursery beds with pests.

*Actions to prevent nursery contamination*

There are five main entry points for pathogens into the nursery:

propagation facilities: containers, flats, knives, secateurs, working surface, boxes etc.

**Damping-off**

Probably the best-known nursery disease of all is *damping-off*, which is caused by several species of fungi, particularly *Pythium*, *Rhizoctonia*, *Phytophthora* and *Fusarium*.

Damping-off can occur on seed before germination, or on young seedlings.

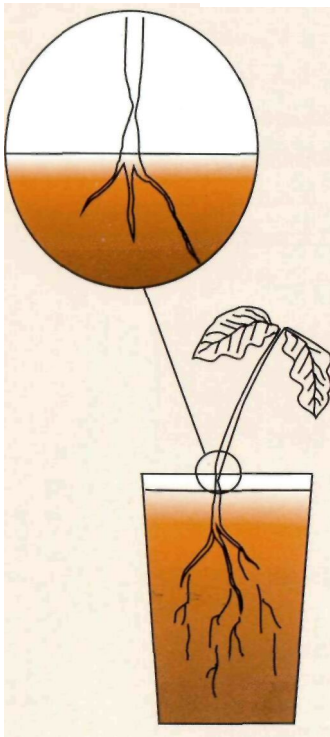

When it happens, the stem of the seedling becomes constricted just above the surface of the germination substrate, and then the seedling falls over and dies. (Sometimes this can happen without any fungi present, for example, with high temperatures of the propagation medium.) There is often (but not always) damage to the plant beneath the soil surface as well. The reason for symptoms appearing at the soil surface are not well understood but might be related to the point where the plants start photosynthesizing or where aerobic/anaerobic conditions are conducive to the more virulent stages of the life cycle of the fungus.

Pathogens which cause damping-off, particularly *Pythium*, *Rhizoctonia* and *Phytophthora*, can be spread in the irrigation water. High plant density, overwatering and heavy shade favour the spread of the disease and should be avoided.

- propagation substrates
- irrigation water
- planting stock: seeds, cuttings, scions and rootstocks
- shoes and clothing of nursery staff and visitors.

Plant hygiene begins before propagation, by paying attention to these five entry points.

***Propagation facilities***

- Keep the nursery area itself free of weeds. Many plant species can be alternate hosts of important nursery pests. This precaution includes a sensible selection of ornamentals, shade, hedge and windbreak plants in and around the nursery, as they too can be hosts for pests such as nematodes.
- Treat all wooden supports with old engine oil or chemicals against termite attack. If possible, place propagation structures onto a slab of concrete.
- Keep tools, work surfaces and containers clean at all times. Take particular care with proper sterilization of containers, especially when these are reusable ones. Root diseases such as *Fusarium* root rot can be transmitted through diseased root segments grown into the wall of styrofoam containers. Some tools and containers can be autoclaved but the necessary equipment is not always available.

Keep the nursery area free of weeds and keep tools, work surfaces and containers clean at all times.

One of the most satisfactory and readily available chemicals for sterilizing nursery equipment is chlorine, the active ingredient of household bleach. Chlorine is a very irritating gas with a pungent odour. It evaporates easily and its smell can be detected in very low concentrations (0.2-0.4 ppm); in higher concentrations it irritates eyes, nose and throat. It is a strong oxidizing agent and kills organisms by chemically 'burning' their tissue. It is usually diluted in water. The usual form of chlorine in household bleach is as the sodium salt, sodium hypochlorite (NaOCl). Commercial household bleach contains 3.5% NaOCl in water. To use it as a sterilant, make a 10% solution (1 part bleach to 9 parts water) and soak instruments or containers in it for at least 30 minutes. The use of a few drops of washing up liquid helps prevent air bubbles next to the surface. Chlorine is deactivated by dirt particles. Therefore clean all material to be sterilized thoroughly before putting it into the solution. Make a fresh solution each time you need it, and replace when dirty.

## Section 5

Use 10/o and household sterilize tools and containers.

Chlorine is a contact sterilizer and has no systemic functions. It can only kill organisms that are exposed to it such as those suspended in the solution or on the surface of the equipment. Therefore, it is a good idea to soak containers and other equipment in water for 24 hours before sterilizing so that fungal spores, for example, can germinate which makes them more susceptible to the treatment. A 10% bleach solution is also used to sterilize bench surfaces and other work surfaces.

The disposal of used chlorine solutions may be a problem: the hypochlorite ion attaches to organic compounds in the soil, can be taken up in the food chain and can accumulate in the body fat of animals and humans. This can pose a serious problem when large amounts of chlorinated water needs to be disposed of. A practical solution for small amounts is to let a container with chlorinated water stand until it does not smell of chlorine any more.

*Note: As with any other chemical disinfectants, chlorine is a hazardous substance and misuse can lead to serious injury or even death. Use only in well-ventilated areas.*

A less hazardous alternative to chlorine is hydrogen peroxide ( $H_2O_2$ ), which breaks down to water and oxygen. Use 1 part commercial  $H_2O_2$  (35%) to 100 parts water. Other disinfectants frequently used, especially in the laboratory, are formalin, mercuric chloride and 70% alcohol. These are all more expensive than bleach, and in addition, formalin and mercuric chloride are extremely poisonous and are suspected carcinogens.

### *Propagation substrates*

When substrates, in particular soil and organic material, are brought into a nursery, they provide easy ways for pests to come too. In bare-root nurseries or when practising open-ground propagation, pests may accumulate in the soil and make large-scale treatments or, in extreme cases, a move to a new location, necessary.

The standard treatments for substrates are either chemical fumigation or sterilization with hot steam or sunlight. Chemical fumigation with methyl bromide or related chemicals is very hazardous and expensive. Methyl bromide

is highly toxic to humans and it destroys the earth's ozone layer. It is scheduled to be banned worldwide, although this ban will not be effective in most countries until 2010. We therefore strongly discourage the use of methyl bromide. Environmentally safer options are sterilization (correctly called 'pasteurization' because it is not a complete process) with either hot steam or sunlight ('solarization'), or selective treatments with herbicides or fungicides if necessary.

Substrates that have been manufactured using high temperatures, such as vermiculite or perlite, do not need to be sterilized **unless they are recycled**. For storage of sterilized substrates, use only clean and disinfected containers.

For storage of sterilized substrates, use only clean and disinfected containers.

### Soil pasteurization treatments

#### steam pasteurization

Soil sterilization with aerated steam is preferred to fumigation with chemicals. However, steam is not selective and kills beneficial organisms as well as pathogens. Specialized equipment for steam pasteurization is not always available. A practical and simple alternative can be made using a clean oil drum: insert a strong mesh or grid at about 1/3 its height from the bottom, for example by welding iron rods at close spacing. Put the drum onto stone feet, fill with water up to the grid and place the substrate in sacks on top of the grid. Cover the drum, light a fire under the drum and keep burning for 2-4 hours. Ensure that the temperature of the substrate reaches 60°C for 30 minutes. This will kill most plant pathogenic fungi and bacteria, as well as nematodes, but only a few viruses, plant insects or weed seeds. If you need a more complete treatment, raise the temperature to 80°C and hold this for 30 minutes. However, at this temperature, so many beneficial organisms will be killed that this may lead to an explosive re-colonization of the substrate with pathogens.

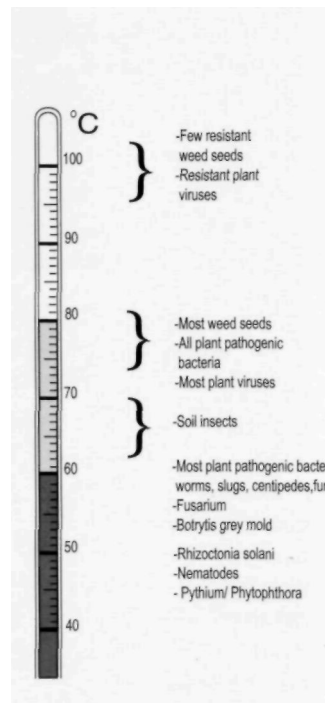

#### solarization

Solarization can be carried out in any nursery. Cover moist soil with transparent polyethylene sheets and weigh them down with rocks. On sunny days, the temperature under the plastic sheet will reach 70°C or more. However, this pasteurization affects only the first few centimetres of soil and under cloudy conditions it *can* take several weeks for a successful treatment.



## Section 5

A small amount of chlorine to provide a 1 ppm concentration for at least 30 minutes can be added to the irrigation water to control damping-off fungi.

Diseased plants in a nursery should be culled rigorously and burnt rather than composted.

***Irrigation water***

Water for irrigating in nurseries often comes from a dam, a borehole or a tank filled with rain water. These stagnant reservoirs provide excellent conditions for water mould fungi — species of *Pythium* and *Phytophthora* — which are commonly associated with damping-off. A small amount of chlorine to provide a 1 ppm concentration for at least 30 minutes can be added to the irrigation water to control damping-off fungi. (Swimming pool water has a maximum concentration of 8 ppm available chlorine).

**Disinfecting irrigation water**

Household bleach usually has a strength of 3.5% or 35 000 ppm NaOCl. It contains 24 000 ppm chlorine (Cl<sub>2</sub>). To make 1 L of a 1 ppm Cl<sub>2</sub> dilution, 0.042 ml (or 42ul) of household bleach is needed. For a 20 L bucket, 20 x 0.042 = 0.84 ml. A 10 000 litre water tank would need 420 ml. If the water contains a lot of sediment or other dirt particles, up to twice as much will be needed. In any case, the amount needed for treating irrigation water to check diseases like damping-off is very small, and this makes nursery hygiene affordable and simple.

***Planting stock***

Plant material from other nurseries (seed, cuttings, scion wood and rootstock) can harbour nursery pests. Wherever possible, accept propagation material from nurseries only if it has a plant inspection certificate. If in doubt, surface sterilization should be carried out on all new and unknown material.

Diseased plants in a nursery should be culled rigorously and burnt rather than composted. Composting diseased material can only be recommended if the compost temperatures are high enough to kill pests (above 60°C), and can be maintained at this level for several days.

***Shoes and clothing***

Quite often, diseases are brought into a nursery inadvertently on shoes (soil-borne diseases and nematodes) or clothing (weed seeds). This is very

difficult to control. The best way is probably to issue to staff boots and work clothes to wear during work in the nursery and to install a dip basin with 10% household bleach solution at the entrance of the nursery through which staff and visitors have to walk to disinfect their shoes, especially when they come from fields where soil-borne diseases or nematodes are present.

### Methods of surface sterilization

#### heat

For seeds, tubers and roots, hot water soaks (40-55°C) are recommended. Temperature and duration depend on the species. You can find the best range with simple experimenting, for example by soaking material at two different temperatures for half an hour, two hours and four hours.

#### chlorine

Dipping cuttings into a 10% household bleach solution for 20 minutes is a practice recommended for some hardwoods but it should be tested for phytotoxicity on all species first.

#### fungicides

Seeds or cuttings can be coated with a dust or slurry of fungicides. Captan® and Benlate® are the most commonly used fungicides for seed treatment. Captan® is a contact fungicide which kills pathogens present on the seed coat; Benlate® is a systemic fungicide which penetrates into the seed and has an effect on the embryo during germination, giving the seed a longer-lasting protection. However, most fungicides have a high toxicity to seeds and they often act only on one of the number of pathogens that are usually present. Recent work suggests that coating the seed with a bacterial formulation, esp. *Trichoderma harzianum* or *Pseudomonas* spp., would be helpful. However, for the time being, this technique is out of reach for most institutions in developing countries.

### Section 5

#### **Actions to prevent nursery contamination**

##### **plant health status**

Healthy, well-fertilized and properly irrigated plants are better suited to withstand pest attacks. However, over-fertilizing should be avoided, especially excess nitrogen, which weakens plants and makes them more attractive to many sap-sucking insects, such as aphids and psyllids.

##### **plant density**

Avoid very dense spacing in germination and nursery beds, because diseases can spread easily. Close spacing can also lead to etiolated and weak plants which are susceptible to disease.

##### **hardening**

Timely hardening of seedlings will produce strong and healthy plants that are able to withstand a certain amount of pest or disease attack.

##### **resistant species or cultivars**

If possible, grow resistant types or cultivars, or avoid susceptible species altogether. For example, citrus should not be propagated in areas with high incidence of aphids, since aphids transmit citrus greening disease, and spraying against the aphids usually cannot check the problem to the necessary extent.

##### **cleanliness in vegetative propagation**

When harvesting scionwood and cuttings, take care that they come from healthy stock plants that are not depleted of nutrients or drought stressed, to enhance their resilience to diseases. Always sterilize knives and secateurs with alcohol to avoid spreading virus diseases, which are often transmitted on the tools.

##### **staff training**

To keep pest and disease levels low, all employees should be trained to recognize and report pests. Workers who are in daily close contact with the plants through watering, weeding etc., will probably more often encounter such problems than a nursery manager would.

*Actions to cure infected plants*

In instances of pest or disease attack, you will have to decide whether to use physical, biological or chemical pest management.

In areas where manual labour is readily available, and when the incidence is not very severe, collecting of pests or diseased leaves from the seedlings by hand and destroying them may be practical. Biological agents such as parasitic wasps can be used but they are not available everywhere. Successful studies with various agroforestry tree species, such as *Gliricida sepium*, *Erythrina* spp., *Calliandra calothyrsus* and *Leucaena leucocephala* have been carried out by the Institute of Biological Control, the International Centre for Insect Physiology and Ecology and other institutions which can provide more information.

However desirable the use of biological methods, chemical sprays or drenches are still in most cases the methods of choice. These pesticides act quickly, and often they are selective so they do not destroy beneficial organisms. For important horticultural crops in temperate zones, pest occurrence thresholds have been published, below which the use of pesticides is not recommended. For tropical trees, notably agroforestry tree species, no such thresholds exist. We recommend that nursery managers develop them for their local conditions. For example, you could decide to spray with an insecticide against aphids only if these are detected on more than half of the stock, or to use a miticide against spider mites only if more than 10% of plants show symptoms. Of course these thresholds depend on the species and their susceptibility to the pests, and developing them requires intimate knowledge of the species.

In areas where manual labour is readily available, and when the incidence is not very severe, collecting of pests or diseased leaves from the seedlings by hand and destroying them may be practical.

*Further reading*

- Evans J. 1982. Plantation forestry in the tropics. Oxford Science Publications. Oxford, UK: Oxford University Press. 472 pp.
- Hartmann HT, Kester DE, Davies FT and Geneve RL. 1997. Plant propagation. Principles and practices. Sixth edition. London. UK: Prentice Hall International. 770 pp.
- Landis TD. 1994. Using chlorine to prevent nursery diseases. Forest Nursery Notes 7-94. (source: [http://willow.ncfes.umn.edu/fnn\\_7-94/iprn794.htm](http://willow.ncfes.umn.edu/fnn_7-94/iprn794.htm))
- Landis TD, Tinus RW, McDonald SE and Barnett JP. 1989. The Biological Component: Nursery pests and mycorrhizae. vol. 5, The container tree nursery manual. Agriculture Handbook 674. Washington, DC, USA: US Department of Agriculture, Forest Service. 171 pp.
- Schauer T. 1996. Methyl bromide: an international inconsistency? In <http://www.brobeck.com/docs/methyl.htm>. Brobeck, Phleger and Harrison environmental law practice.
- Sing Rathore, MP. 1995. Insect pests in agroforestry. ICRAF Working Paper no. 70. Nairobi, Kenya: ICRAF. 73 pp.

# Section 6: Nursery environment and facilities

In this section, we discuss equipping an agroforestry tree nursery with enclosed structures, irrigation systems and shading. Not every nursery needs glass-houses or an automated irrigation system, but it is important that you know about their existence, their benefits to plant production, and their requirements in installation and maintenance.

Seedling growth is affected by conditions both above-ground — humidity, carbon dioxide, temperature and light — and below-ground — water and mineral nutrients. Other organisms, either beneficial or harmful, can influence plant growth. The below-ground factors have been discussed in the preceding sections. Depending on the needs of the project, more or less sophisticated equipment can be installed into the nursery in order to optimize the atmospheric factors. Almost anything is possible — but what is really

necessary? Improving the nursery standards by providing a reliable water supply, uniform shading, and protected propagation and weaning areas can help greatly to produce uniform and healthy stock. Increased investment in nursery production is almost always recovered in increased plant survival and productivity. Controlling the atmospheric environment, on the other hand, may be necessary only in specific cases.

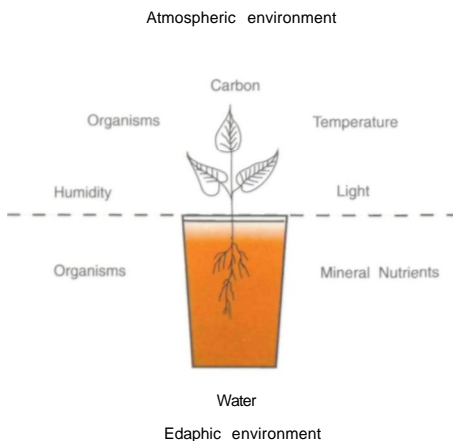

Section 6

*Nursery layout*

Firstly, draw up a 'material flow chart': list all materials coming in (substrate, seed, containers etc.), where they will be stored, where they will be used, how they will be moved. List also what is going out of the nursery (seedlings) and from where. Incoming materials should be divided into toxic and non-toxic and into wet and dry. Keep the different types apart and keep toxic materials some distance from any plant growing area.

The whole nursery area needs to be well-drained.

Avoid water-logging at all costs.

For seedling production, there are two distinct areas needed in a nursery: one in which close monitoring of temperature, light and humidity can be guaranteed for seed germination and for rooting cuttings; and one for hardening plants and preparing them for field planting. A germination area will be relatively small and can contain a number of enclosures, depending on the size of the operation and the species worked with: propagation boxes, polytunnels or glasshouses. The hardening area usually consists of areas under various degrees of shade, and an open area where plants are grown under full sunlight.

The whole nursery area needs to be well-drained. Avoid waterlogging at all costs. Put a 5-cm layer of medium gravel on the ground for good drainage and to control weed growth. Install benches to facilitate the operations. When using root trainers, frames need to be constructed at a convenient height for working, but at least 30 cm off the ground.

*Enclosed structures*

The need for enclosed structures varies greatly with the climate. In humid locations, structures may be needed only to provide shade or to keep pests out, whereas under arid conditions enclosures are needed to maintain a higher humidity for germinating seed, rooting cuttings and successful grafting. Although automated misting systems may be desirable for many projects, simple structures enclosed in polyethylene, such as a polypropagator or a polytunnel, are sufficient in most cases where small numbers of plants are produced. These low-cost techniques-consider the restrictions of rural communities, which often do not have easy access to water, electricity and other materials. Their drawbacks are a large fluctuation in air humidity and a lack of air circulation which benefits pathogen development.

In Andra Pradesh, India, a modified polypropagator has been perfected. Holes 1.5 m x 1.5 m x 1 m deep are lined with polythene and filled with a 20 cm layer of gravel which acts as a reservoir. The gravel is covered with 10 cm of washed sand for rooting. A tube into the gravel is used to top up the reservoir as required. The whole propagator is covered by a polythene-covered hooped 'roof'. A small flap in the polythene permits misting by hand with a pressure backpack.

For small operations (less than 5000 plants a year) a few propagator boxes (polypropagators) are sufficient. These boxes can be made to varying specifications. A recommended size is 2 m long, 1 m wide and 0.5-1.5 m high, with a slanting lid. Note the layers of stones, gravel and rooting substrate. Whether or not the box is completely enclosed in polyethylene, i.e. including the bottom, depends on the conditions and the main use. For propagating cuttings, a complete enclosure is recommended to guarantee a very high air humidity; for seed germination or grafts, an open bottom with better drainage is acceptable. Boxes should be arranged with the long axis aligned east-west to allow for even illumination, and the lid sloping from south to north in the southern hemisphere (north to south in the northern hemisphere) to gather maximum light.

For larger operations or larger plants, walk-in structures like tunnels made from semi-circular steel rods can easily be put up, using locally available materials.

Both propagation boxes and walk-in tunnels are usually covered with polyethylene sheeting. Polyethylene transmits about 85% of the sun's light and allows through all

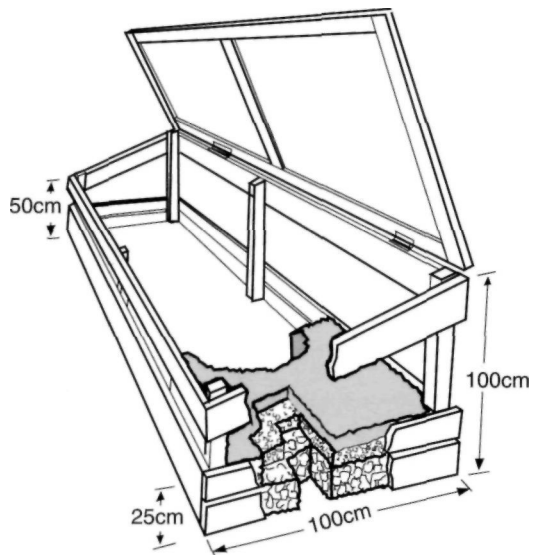

A polypropagator. Note the layers of stones, gravel and rooting substrate.



Section 6

Sheeting with UV stabilizer can last up to 3-5 years under tropical conditions, whereas untreated material may need to be replaced after a few months.

wavelengths necessary for healthy plant growth. It is slightly permeable to CO<sub>2</sub> and oxygen, but it reduces the passage of water considerably. Polyethylene breaks down in sunlight, therefore the use of UV-stabilized material is recommended. Sheeting with UV stabilizer can last up to 3-5 years under tropical conditions, whereas untreated material may need to be replaced after a few months. This needs to be taken into account when calculating costs.

Although polyethylene is more permeable than glass to infra-red radiation, heat builds up inside a propagator or tunnel. Large temperature fluctuations between day and night are common. Use opaque polyethylene and/or shade the structure to avoid this problem.

Other materials for covering greenhouse structures are glass, which has excellent properties but is fragile, and various plastic materials. These materials are usually much more expensive than polyethylene film.

The high air humidity, high temperatures and generally stagnant air inside closed structures are extremely conducive to fungal growth. Extra care

<b>Cover materials and their properties</b>	
<b>glass</b>	good light transmittance, fragile, heavy
<b>polyvinyl chloride (PVC)</b>	strong, low light transmittance, degrades under UV
<b>polyethylene</b>	relatively cheap, comes in many sizes, degrades under UV unless stabilized
<b>acrylic</b>	excellent light transmittance, scratches easily, highly flammable
<b>fibreglass-reinforced polyester</b>	low cost, strong, yellows with age, highly flammable

is therefore needed to monitor for pests inside enclosed propagation structures. Provide sufficient ventilation, for example by opening the ends or by constructing the sides so that they can be rolled up.

## Water

Water is the single most important factor in plant production. Seedlings contain over 95% water. The production calendar in tropical countries is determined by the rainy season, rather than by rising temperatures as it is in temperate regions. Proper irrigation and the maintenance of high humidity in the propagation environment are prime responsibilities of a nursery manager.

Various irrigation systems have been developed locally. **Gravity-fed systems** are preferred by many small local nurseries in remote locations. However, for controlled irrigation a reliable water source supplying piped water year-round is absolutely necessary. Watering should be done with a hose pipe that has a nozzle with fine holes so that young seedlings do not get damaged. Regulating water output with a thumb on the hose pipe is not acceptable because the distribution of water is too variable. The addition of a 60 cm metal rod to the hose makes targeted watering of containers easier and saves water. If water pressure and water quality allow it, consider installing an **automated irrigation**

For controlled irrigation a reliable water source supplying piped water year-round is absolutely necessary.

Mist propagation has major benefits in tropical climates: water is sprayed in very fine droplets in short intervals onto the plants, where it evaporates. A surface from which water evaporates is cooled because vaporization of liquid water to water vapour is energy consuming. This is also the principle behind mist propagation: the water vapour helps to cool the leaf surface so that stomata stay open even in a warmer environment and assimilation can proceed unhindered — allowing increased plant growth. It is important to note that the mist does not irrigate the plants but prevents excessive transpiration by the green shoots, thereby preventing desiccation.

The amount of water which air can hold depends on the temperature of the air. Once the air is saturated, water condenses, i.e. accumulates in drops. Cold air can hold less water before it condenses than warm air. This is why condensation occurs first on colder surfaces. The relative humidity inside a non-mist propagator can fluctuate between 100% during the night and below 50% at midday if the structure is kept closed and no additional moisture is provided during the day. This effect may be reduced by avoiding large temperature fluctuations, for example by providing bottom heat during the night and extra shading during the day. The condensing water inside the lid can reduce the light reaching the plants considerable and needs to be wiped off frequently.

Section 6

Use good-quality shade cloth to provide durable and uniform shade to the seedlings.

**system** for even application of water. Especially in arid areas, **drip irrigation** is advisable to reduce evaporative losses. This system distributes water directly to the roots and therefore saves considerable amounts of water. Automated irrigation needs clean water so filters are necessary. High amounts of calcium or magnesium can clog the nozzles and make frequent washing, or the addition of low concentrations of acid (for example vinegar), necessary. The necessary information about irrigation systems should be obtained from qualified suppliers (See Annex 1 for examples).

Water quality is important for healthy plant development although often there is no way of changing it. Saline water should be avoided unless salinity-tolerant crops, such as *Casuarina* or *Prosopis*, are produced. Treating water with low concentrations of chlorine (1 ppm) helps control water moulds (see page 60).

*Light*

The right amount of light is critical for healthy plant development of seedlings. Too much shade, for example in high plant densities, leads to etiolated and elongated growth of the seedlings and makes them weak and prone to fungal diseases. Too much light leads to sun scorching and drying out of the tender tissue. Use good-quality shade cloth to provide durable and uniform shade to the seedlings. Avoid using grass, reed or bamboo mats as they are not

<b>Effect of shade on air and leaf temperature</b>			
	<b>Light intensity (umol/m<sup>2</sup>/s)</b>	<b>Air temperature (°C)</b>	<b>Leaf temperature (°C)</b>
<b>unshaded</b>	<b>1370</b>	<b>36</b>	<b>40</b>
<b>50% shade</b>	<b>525</b>	<b>32</b>	<b>32</b>

durable, do not provide uniform shade, and can harbour pests and diseases. Nursery managers must decide whether shade should be permanently installed and plants moved from one shade level to another, or whether the plants should remain in position and the shade be moved.

Shade cloth is usually woven from nylon (polypropylene) thread, but cheaper cloth made from saran (polyvinylchloride) is also available. Saran shrinks about 3% and needs to be installed with a slight sag. Shade cloth is available in various densities from 30 to 95% shade. It is usually black, but also comes in green or red; these colours change the wavelength of the transmitted light and thus influence plant development (see below). Aluminium-covered thread is used to make cloth that reflects the infra-red wavelength from the sunlight and keeps the shaded area cooler. Shade cloth made from nylon can last over 10 years under tropical conditions.

Use the higher densities of shade cloth (80-60%) for young seedlings, and lower densities (40-30 %) for older ones. You can either arrange two or three areas with different shade densities and move seedlings as required, or have several layers of shade cloth which can be removed as needed.

Light quality (red:far-red ratio) can affect plant growth and can be used to manipulate stock plant management, seed germination and shoot development. Vegetative growth is enhanced when the light quality is changed towards the red spectrum with green netting. When it is changed towards the blue/green using red netting, flowering can be induced. Coloured netting is not used on a routine basis in agroforestry tree nurseries but an easy way to change the light quality favourably for vegetative growth, for example in stock plant management for cuttings, is to grow plants under a light shade of small-leaved species, such as *Calliandra* or *Leucaena*.

Day length is not critical for the production of tropical species, but an artificial change of photoperiod can influence root initiation in cuttings, and carbohydrate reserves in some species. The installation of lamps over part of the propagation area may be justified in experimental settings.

## Section 6

Note that three layers of 20% shade cloth do not necessarily provide a 60% shade, because they usually do not exactly overlap. Use a PAR meter<sup>1</sup> to ensure the correct amount of shade. The netting should be fixed above head height (ca 2 m) and run down the east and west sides to provide even shading and yet allow easy access to seedlings. If necessary, you can install additional layers of low shade at plant height. The netting should be supported on wooden beams or strong wires spread between poles at distances of 4-5 m or as convenient for the nursery. Wires are better than wooden beams because they shed less shade on the plants.

### *Temperature*

The temperature range for optimal plant development is 25-35°C . Depending on the species and the prevailing humidity, it can be slightly higher, but avoid air temperatures above 40°C. When using any type of black container, the substrate can heat up to temperatures above 50°C in direct sun. This is undesirable and can be prevented by shielding the containers, for example with wooden planks.

The temperature range for optimal plant development is 25-35°C.

In some locations where temperatures can drop below 20°C, you might need to provide additional heating of propagation beds during the cold months. Heating cables or mats which provide bottom heat can easily be installed. If these do not have a thermostat, they need to be switched on and off according to a well-monitored schedule.

Temperatures need to be most carefully monitored and held inside the recommended range during seed germination, rooting of cuttings and graft union formation.

### *Gas exchange*

Rooting cuttings and germinating seedlings have high respiration rates. This means that oxygen is consumed and carbon dioxide released. The proper exchange of these gases is very important for good root development. In heavy soils and under waterlogged conditions, root development is hindered, resulting in the accumulation of toxic amounts of carbon dioxide in the root zone. On the other hand, plants need to take up CO<sub>2</sub> for assimilation through the stomata on the leaves. Plants stressed by drought or nutrient deficiency have their stomata

<sup>1</sup> PAR = photosynthetic active radiation. Suppliers see Annex 1.

closed and cannot assimilate CO<sub>2</sub> properly, and this results in retarded development. Atmospheric air contains about 0.03% CO<sub>2</sub> and 21% O<sub>2</sub>. For specialist purposes, plants can be grown under elevated CO<sub>2</sub> levels of up to 3% to increase production.

In enclosed structures, the ambient level of CO<sub>2</sub> can drop so much that its assimilation through the stomates is slowed down. Opening the doors briefly for ventilation at set intervals can avoid this.

### *Electricity*

Electricity should be available in the nursery so that equipment such as ventilators, heating cables, electrical balances, and data loggers can be installed. If it is not possible to connect the nursery to the main power line, consider using solar panels instead.

Atmospheric air contains about 0.03% CO<sub>2</sub> and 21% O<sub>2</sub>. For specialist purposes, plants can be grown under elevated CO<sub>2</sub> levels of up to 3% to increase production.

### *Further reading*

- Hartmann HT, Kester DE, Davies FT and Geneve RL. 1997. Plant propagation. Principles and practices. Sixth edition. London. UK: Prentice Hall International. 770 pp.
- Landis TD, Tinus RW, McDonald SE and Barnett JP. 1992. Atmospheric environment, vol. 3, The container tree nursery manual. Agriculture Handbook 674. Washington, DC, USA: US Department of Agriculture, Forest Service. 145 pp.
- Landis TD, Tinus RW, McDonald SE and Barnett JP. 1994. Nursery planning, development and management, vol. 1, The container tree nursery manual. Agriculture Handbook 674. Washington, DC, USA: US Department of Agriculture, Forest Service. 188 pp.
- Longman KA and Wilson RHF. 1995. Preparing to plant tropical trees. Tropical trees: propagation and planting manuals vol. 4. London, UK: Commonwealth Science Council. 238 pp.

## Section 7: Nursery management

An essential part of nursery management is planning the production schedules and data collection. We describe four helpful tools: nursery calendars, plant development registers, nursery inventories and records of nursery experiments. These are needed for both production management and research. We also discuss the importance of staff training, particularly in the use of pesticides and general safety issues.

### *Plans and schedules*

Nursery production is highly seasonal. This is particularly pronounced when producing trees for agroforestry research, as the demand for species or numbers of seedlings will vary considerably depending on current research priorities. Flexibility and planning are therefore essential.

There are four main tools for planning nursery operations:

- \* a **nursery calendar** to help plan necessary actions and purchases of seed, supplies and equipment.
- a **plant development register** for collecting species-specific information about seed treatment, germination requirements and duration, plant development, special requirements for potting substrate, watering, shading or disease control.
  - a **nursery inventory** to keep track of the species and numbers of seedlings in different stages of development.
  - a record of ongoing nursery **experiments**.

All four can be maintained in tabular form designed for ease of data capture onto computer programs. Computerized systems have increased the flexibility of data collection and analysis, making it easy for a nursery manager to correlate the collected information to necessary actions rapidly.

## Planning tools

### nursery calendar

A nursery calendar is an essential tool in nursery planning. The date for sowing seeds can be calculated by counting backwards from the anticipated date of planting, taking into consideration the number of days needed for germination and further seedling development until the right stage for planting. Different species have different requirements for the planting out period (before or during the rains). The time in the nursery also depends on the site on which the seedlings are to be planted. Seedlings for drier sites may need to be larger and need more time in the nursery. Customers might need to be reminded of this when they order plant material to meet certain deadlines. It is also worth anticipating problems with poor germination and/or damping-off to allow time to sow a second time.

Once a nursery calendar has been developed, it will help greatly in making decisions about the need for extra labour and requisition of supplies. Consider the likely delays in procuring and shipment of goods, especially when ordering from abroad. Place orders early enough to allow timely arrival.

### plant development register

Keep a register for each species by seedlot, with information about seed sources used, pretreatments, sowing date, time to germination, germination percentage, percentage of germinants pricked out, potting substrate, microsymbionts used (origin and type), plant development and condition under which produced. Include pests encountered and control treatments, if any, as well as data of plant and/or substrate nutrient analyses.

All this information is important for nursery research and might later help explain unexpected results. It can also be used to compare results with published information and alert you to possible problems originating in the nursery, for example if the development is much slower than is reported elsewhere. It might open additional research areas, for example it might lead to trying different substrates, shading or fertilizer treatments. Good documentation about species handling and development is also necessary when staff changes.





**Example of a nursery calendar**

In Muguga, Kenya, the best field planting season is usually between 1 April and 15 May. The researcher wants a *Leucaena* species trial planted with seedlings of about 20 cm size on about 15 April. The nursery manager has calculated the researcher's requirements as shown below.

	<i>Leucaena leucocephala</i>	<i>Leucaena diversifolia</i>	<i>Leucaena trichandra</i>
days needed from pricking out to planting out	100	110	90
days needed from germination to pricking out	12	12	10
days needed from sowing to germination "		8	8
safety margin in case of poor germination or damping off	15	15	15
total days needed	135	145	123
sowing date	1 December	21 November	13 December

**Staff training**

A good nursery operation relies on continuity of staff who are professional, careful and honest. Although the casuals or technical workers do most of the work described here, everyone in the nursery ought to have as much knowledge about agroforestry tree propagation as possible. Understanding — even in a simplified way — the processes in a germinating seed, a rooting cutting or a growing seedling, and the importance of high humidity, watering,

## Section 7

shading, etc. will help prevent many errors in daily work. Only when all workers feel that they are part of the nursery operation, when they understand the part they play and when they feel proud of it, can a tree nursery work efficiently and productively.

Consider staff training as part of your responsibilities. It is not time wasted—it is your investment in a safer and more productive nursery.

All workers, not only those applying the chemicals, ought to know the basics of handling pesticides. Use gloves and safety equipment—this should be standard practice and not something to laugh about.

Staff training can take the form of scheduled courses or of regular (weekly, monthly) staff meetings covering a particular topic. This can be reinforced by repeating explanations of techniques during work.

### ***Further reading***

- International Labour Organization. 1989. Tree nurseries. An illustrated technical guide and training manual. Special Public Works Programmes booklet no. 6. Geneva, Switzerland: ILO. 127 pp.
- Landis TD, Tinus RW, McDonald SE and Barnett JP 1994. Nursery Planning, Development and Management, vol. 1, The container tree nursery manual. Agriculture Handbook 674. Washington, DC, USA: US Department of Agriculture, Forest Service. 188 pp.

# General reading

- ATIK (Agroforestry Technology Information Kit). 1992. Seeds and plant propagation. International Institute of Rural Reconstruction (IIRR), Department of Environment and Natural Resources (DENR) and Ford Foundation (FF). 106 pp.
- Baker FWG. 1992. Rapid propagation of fast-growing woody species. Wallingford. UK: CAB International. 125 pp.
- Burley J and Wood PJ. 1976. A manual on species and provenance research with particular reference to the tropics. Commonwealth Forestry Institute Tropical Forestry Papers no. 10. Oxford, UK. 276 pp.
- Duryea ML and Landis TD (eds.) 1984. Forest nursery manual: production of bare-root seedlings. The Hague/Boston/Lancaster: Martinus Nijhoff/Dr W Junk Publishers. 386 pp.
- El-Lakany MH. 1992. Rapid propagation of fast-growing tree species in developing countries: its potentials, constraints and future development. In: Baker FWG. 1992. Rapid propagation of fast-growing woody species. Wallingford. UK: CAB International. 102-108.
- Evans J. 1982. Plantation forestry in the tropics. Oxford Science Publications. Oxford, UK: Oxford University Press 472 pp.
- Forestry Commission. 1992. Raising trees from seeds and cuttings. Harare, Zimbabwe: Forestry Commission. 41 pp.
- Gachanja SP and Ilg P. 1990. Fruit tree nurseries. Nairobi, Kenya: Ministry of Agriculture. 88 pp.
- Hartmann HT, Kester DE, Davies FT and Geneve RL. 1997. Plant propagation. Principles and practices. Sixth edition. London. UK: Prentice Hall International. 770 pp.
- Holding C, Niemi T, Omondi W, Weru SM and Kamondo BM. 1995. Establishment of seed production units in Nakuru and Nyandarua districts. Nakuru and Nyandarua Intensified Forestry Extension Project Technical Report no. 11. Nairobi, Kenya: FINNIDA in cooperation with The Ministry of Environment and Natural Resources, Forest Department. 33 pp and 76 pp annexes.
- International Labour Organization. 1989. Tree nurseries. An illustrated technical guide and training manual. Special Public Works Programmes booklet no. 6. Geneva, Switzerland: ILO. 127 pp.
- Kasica AF and Good GL (eds.) 1997. Something to grow on. Cornell Cooperative Extension/Dept. of Floriculture and Ornamental Horticulture. Ithaca, USA: Cornell University. URL: <<http://www.cals.cornell.edu/dept/flori/growon/about.html>>
- Landis TD, Tinus RW, McDonald SE and Barnett JP. 1989. Seedling Nutrition and Irrigation, vol. 4, The container tree nursery manual. Agriculture Handbook 674. Washington, DC, USA: US Department of Agriculture, Forest Service. 119 pp.

- Landis TD, Tinus RW, McDonald SE and Barnett JP. 1989. The Biological Component: Nursery pests and mycorrhizae. vol. 5, The container tree nursery manual. Agriculture Handbook 674. Washington, DC, USA: US Department of Agriculture, Forest Service. 171 pp.
- Landis TD, Tinus RW, McDonald SE and Barnett JP. 1990. Containers and growing media, vol. 2, The container tree nursery manual. Agriculture Handbook 674. Washington, DC, USA: US Department of Agriculture, Forest Service. 88 pp.
- Landis TD, Tinus RW, McDonald SE and Barnett JP. 1992. Atmospheric Environment, vol. 3, The container tree nursery manual. Agriculture Handbook 674. Washington, DC, USA: US Department of Agriculture, Forest Service. 145 pp.
- Landis TD, Tinus RW, McDonald SE and Barnett JP. 1994. Nursery Planning, Development and Management, vol. 1, The container tree nursery manual. Agriculture Handbook 674. Washington, DC, USA: US Department of Agriculture, Forest Service. 188 pp.
- Longman KA and Wilson RHF. 1995. Preparing to plant tropical trees. Tropical Trees: Propagation and Planting Manuals vol. 4. London, UK: Commonwealth Science Council. 238 pp.
- Macdonald B. 1986. Practical woody plant propagation for nursery growers. Portland, Oregon, USA: Timber Press. 669 pp.
- Mexal JG. 1996. Forest nursery activities in Mexico. In: Landis, TD and South DB (technical coordinators) National Proceedings. Forest and Conservation Nursery Associations. General Technical Report PNW-GTR-389. Portland, OR, USA: US Department of Agriculture, Forest Service. 228-232.
- Napier I and Robbins M. 1989. Forest seed and nursery practice in Nepal. Kathmandu, Nepal: Nepal-UK Forestry Research Project. 139 pp.
- Poynton S. 1996. Producing high-quality Eucalyptus seedlings using a best practices approach in Vietnam's Mekong-Delta. In: Yapa AC (ed.). Proceedings of the international symposium on recent advances in tropical tree seed technology and planting stock production. Muak-Lek, Saraburi, Thailand: ASEAN Forest Tree Seed Centre. 112-118.
- Shanks E and Carter J. 1994. The organization of small-scale tree nurseries. Studies from Asia, Africa and Latin America. Rural Development Forestry Study Guide no. 1. Rural Development Forestry Network. London, UK: Overseas Development Institute. 144 pp.
- Supriadi G and Valli I. 1988. Mechanized nursery and plantation project in South Kalimantan. Nursery Manual ATA - 267. FINNIDA. 76 pp + 22 pp appendices.
- Wambuguh DAM and Huxley PA. 1990. Multipurpose tree nurseries for research. Nairobi: International Council for Research in Agroforestry (ICRAF). 54 pp.
- Yapa AC (ed.). 1996. Proceedings of the international symposium on recent advances in tropical tree seed technology and planting stock production. Muak-Lek, Saraburi, Thailand: ASEAN Forest Tree Seed Centre. 222pp.
- Zobel BJ, van Wyk G and Stahl P. 1987. Growing exotic forests. New York, USA: J. Wiley and Sons. 508 pp.

# Glossary

## **assimilation**

The process in which plants convert the sun's energy, water and carbon dioxide into sugars and more complex molecules, such as amino acids or other substances important for plant metabolism. Assimilation and photosynthesis are often used synonymously.

## **bare-root seedling production**

Also called 'open ground seedling production'. A system in which seedlings are grown directly in the soil and lifted for transplanting without any of the growth substrate attached to the roots (in contrast to **container production**). More common in humid and temperate than in arid environments.

## **bulk density**

The weight of something per unit volume. In a nursery, bulk density is usually expressed as  $\text{kg/m}^3$  or  $\text{g/L}$ . The higher the bulk density, the heavier the material.

## **container plant**

A nursery plant that is grown in a container. It refers to seedlings after **pricking out** and rooted cuttings after potting.

## **container production**

Plant production which uses any sort of suitable container, from polythene bags to rigid clay or plastic containers (**root trainers**).

## **cotyledons**

The primary leaves of germinating plants ('seed leaves').

## **culling**

The process of selecting and eliminating plants that do not meet requirements, such as the weak, diseased, or retarded plants. Culling includes discarding plants that grow faster than the norm.

## **direct sowing**

The planting of seeds directly into the container. This practice avoids **pricking out** and often results in faster plant development without the likelihood of root deformities.

<b>etiolation</b>	The response of a plant to insufficient light. Plants react to dark conditions by growing long internodes and reducing chlorophyll from the tissues. Plants that are etiolated have soft stems and are prone to physical damage or insect attack. When planting density is too high etiolation results from this too. Etiolation is sometimes used as a pre-treatment in rooting cuttings.
<b>flat</b>	A shallow tray, usually rectangular, with or without holes and/or compartments. Flats are normally used as germination trays or for <b>plug</b> production.
<b>germplasm</b>	Any plant part used for regeneration: seed, cuttings, scions, pollen. <b>Symbionts</b> necessary for a tree's survival are often included in 'germplasm'.
<b>hardening-off</b>	The process of adapting seedlings to field conditions by <i>gradually</i> withholding water and shading.
<b>medium (pi. media)</b>	see <b>substrate</b>
<b>orthodox seed</b>	Seed that can remain viable for long periods if processed and stored in the appropriate manner (normally seed should have a low moisture content and be kept at low temperatures).
<b>PAR</b>	<i>Photosynthetically active radiation</i> , the wave lengths between 380 and 720 nm that can be used by plants for photosynthesis.
<b>planting stock</b>	Or simply 'stock'. The plants being produced in the nursery.
<b>plug</b>	A seedling or cutting that has been grown in a root trainer and whose root mass has filled the container completely.
<b>ppm</b>	<i>Parts per million</i> , e.g. 1 g in 1 000 000 g or 1000 kg, or 1 ml in 1000 L. Used to express concentrations of fertilizer or pesticide formulations.

<b>pricking out</b>	Planting seedlings from the germination bed into pots. This should be done as early as possible after germination, before roots grow so long that they could be damaged in the process. Pricking out is usually done with species which have very small seeds and seedlings which need special attention. Pricking out can lead to <b>root deformities</b> when not done very carefully.
<b>provenance</b>	<b>Germplasm</b> from a single place of origin. Germplasm from different provenances of the same species can differ in ways such as growth habit, biomass production, or drought hardiness.
<b>recalcitrant seed</b>	Seed that cannot be dried to a low moisture content without losing viability (as compared to <b>orthodox seed</b> ).
<b>root deformity</b>	Any abnormal form of a root system, such as bent (J, L-form), double bent (N-form) or coiled roots. These are caused by the container, bad <b>pricking out</b> or overgrowing, and can be limited by the use of <b>root trainers</b> .
<b>root trainer</b>	Any rigid container that has vertical ribs to direct root growth, and one or more large holes at the bottom for air root pruning. Root trainers are made in different shapes (round, square, octagonal) and depth. The original Roottrainers® can be opened like a book for easy extraction of the seedlings.
<b>shade cloth</b>	A netting woven from nylon or saran thread. A particular grade of shade cloth transmits a certain amount of the sun's light. Coloured netting can be used to change the wavelengths of sunlight in the red: far-red ratio.
<b>shade house</b>	An open construction with <b>shade cloth</b> spread over wires stretched between poles. Shade houses are usually 3-5 m high.
<b>substrate</b>	The material in which a plant grows. Used synonymous with 'medium'.



- Symbiont** Any member of a group of micro-organisms or fungi that grows in close association with its host plant. Symbiotic associations benefit both host and symbiont: the host plant provides the symbiont with energy through assimilates; the symbiont provides the host plant with nutrients. The most common symbionts on agroforestry trees are *Rhizobium*, *Frankia* and mycorrhizae.
- UV** Ultraviolet radiation (5-400 nm). The main source for UV radiation is the sun. It is invisible to the human eye but can cause skin cancer, and plastic exposed to UV deteriorates rapidly unless the material has been UV-stabilized through a special chemical process.
- wind-throw** The falling of trees in strong winds, often due to a weak, distorted or shallow root system. It is worth excavating and examining fallen trees to see whether the cause was a badly developed root system.

# Annex 1: Nursery suppliers

<b>general horticultural suppliers</b>		
<b>supplier</b>	<b>contact</b>	<b>products</b>
Hermann Meyer Postfach 1351 D-25454 Rellingen GERMANY	tel: +49 4101 49090 fax: +49 4101 490939 email: mail@hermann- <a href="mailto:mail@hermann-meyer.de">meyer.de</a>	all nursery supplies, tools and equipment
Amiran Kenya Ltd. PO Box 30327 Nairobi KENYA	tel: +254 2 556564 +254 2 543506-7 fax: +254 2 543445	shade cloth, irrigation systems, fertilizer, greenhouse covering
Farm-A-Rama Pvt.Ltd. Box 158 Marondera ZIMBABWE	tel: +263 79 23086 +254 2 21204 fax: +263 79 24304	nursery tools, labels, chemicals, fertilizers, rooting hormone, containers
Farm & City Centre Box 510 TA Harare ZIMBABWE	tel: +236 4 728551 fax: +236 4 728570	nursery tools, shade cloth, fertilizers, chemicals, plastic and paper bags, rooting hormone
Highfield Bag Pvt. Ltd. Box Harare ZIMBABWE	tel: +263 4 620691 +263 4 620696	plastic bags and sheeting, shade netting and vegetable pockets, twines, disposable gloves
Agricultural Trading Company PO Box 5150 Limbe MALAWI	tel: +265 640917	all nursery and agricultural supplies

ANNEX 1 : NURSERY SUPPLIERS

<b>greenhouse technology including shading</b>		
<b>supplier</b>	<b>contact</b>	<b>products</b>
Campbell Scientific Ltd. Campbell Park Shepshed, Leics. LE12 9RP UK	tel: +44 1509 601 141 fax:+44 1509 601091	data loggers, weather stations, sensors
Delta-T Devices Ltd. 128 Low Road Burwell Cambridge CB5 0EJ UK	tel: +44 1638 742922 fax: +44 1638 743155	environmental and plant science instruments, data loggers, soil moisture probes, evapotranspiration measurement
M.H. Berlyn Co. Ltd. Concord House Providence Drive Lye, West Midlands DY9 8HO UK	tel: +44 1384 896666 fax: +44 1384 896668	soil warming cables
Rolloos Sorensen B.V. Krabbescheer 6 Postbus 162 4940 AD Raamsdonksveer HOLLAND	tel: +31 162 574574 fax: +31 162 574500 email: <a href="mailto:rovero@tip.nl">rovero@tip.nl</a>	greenhouse technology
BCC AB Profilgatan 15 S-261 35 Landskrona SWEDEN	tel: +46 418 449920 fax: +46 418 449922 email: <a href="mailto:bcc@bccab.com">bcc@bccab.com</a>	root trainer systems, greenhouse and climate control, irrigation and fertilizer systems
Highfield Bag Pvt. Ltd. Box Harare ZIMBABWE	tel: +263 4 6206961 +263 4 620696	fertilization systems
Shade Net Ltd. PO Box 64107 Nairobi KENYA	tel: +254 2 0760997/38 fax: +254 2 762401 email: <a href="mailto:shadenet@africaonline.co.ke">shadenet@africaonline.co.ke</a>	nets and drip irrigation for agriculture and horticulture

## ANNEX 1: NURSERY SUPPLIERS

<b>irrigation technology</b>		
<b>supplier</b>	<b>contact</b>	<b>products</b>
Hobra Manufacturing Ltd. POBox 1187 Naivasha KENYA	tel: +254 311 30440/2 fax: +254 311 21082	hand sprayers, motor sprayers
BCCAB Profilgatan 15 S-261 35 Landskrona SWEDEN	tel: +46 418 449920 fax: +46 418 449922 email: <a href="mailto:bcc@bccab.com">bcc@bccab.com</a>	root trainer systems, greenhouse and climate control, irrigation and fertilization systems
Shade Net Ltd. PO Box 64107 Nairobi KENYA	tel: +254 2 760997/38 fax: +254 2 762401 email: shadenet@africaonline.co.ke	nets and drip irrigation for agriculture and horticulture

<b>containers</b>		
<b>supplier</b>	<b>contact</b>	<b>products</b>
Ronaash Ltd. Kersquarter, Kelso Roxburgshire TD5 8HH UK	tel: +441573 225757	root trainers
Jiffy International AS Storgaten 2 N-1440 Drobak NORWAY	tel: +47 64 935130 fax: +47 64 931311 email: <a href="mailto:a.beisland@jiffy.no">a.beisland@jiffy.no</a>	jiffy pots and pellets
Plastech Designs Pvt. Ltd. Box 5354 Southerton Harare ZIMBABWE	tel: +263 4 755730 fax: +263 4 755731	blow-moulded containers, plastic packaging
BCC AB Profilgatan 15 S-261 35 Landsfrona SWEDEN	tel: +46 418 449920 fax: +46 418 449922 email: <a href="mailto:bcc@bccab.com">bcc@bccab.com</a>	root trainer systems, greenhouse and climate control, irrigation and fertilization systems

ANNEX 1 : NURSERY SUPPLIERS

<b>Rhizobium and mycorrhiza inocula</b>		
<b>supplier</b>	<b>contact</b>	<b>products</b>
CSIRO Plant Industry GPO Box 1600 Canberra, ACT 2601 AUSTRALIA	tel: +61 6 2465093 fax: +61 6 246500	<i>Rhizobium</i> cultures
University of Alberta Microfungus Collection Devonian Botanic Garden Edmonton, Alberta T6G 2E1 CANADA	tel: +1 403 9874811 fax: +1 403 9874141	Mycorrhiza cultures
Tropical Forest Research Institute Forest Pathology Division PO RFRC Mandla Road Jabalpur (MP) 482021 INDIA	tel: +91 761 322585 +91 761 84746 FAX:+91 761 321759	<i>Rhizobium</i> and mycorrhiza cultures
NifTAL Centre 1000 Holomua Avenue Paia, Maui Hawaii, 96779 USA	fax: +1 808 5798516 email: <a href="mailto:nifTAL@hawaii.edu">nifTAL@hawaii.edu</a>	<i>Rhizobium</i> cultures

<b>chemical products</b>		
<b>supplier</b>	<b>contact</b>	<b>products</b>
Griffin Co. PO Box 1847 Valdosta, GA 31603 USA	fax: +1 912 2428635	pesticides and Spin-Out for copper coating containers
Scotts Professional Business Group Paer Mill Lane, Bramford, Ipswich, Suffolk, IP8 4BZ UK	fax: +44 1473 830046	Osmocote slow release fertilizers; other fertilizer products

## Annex 2: Useful Internet addresses

<http://iufro.boku.ac.at/iufro/iufro.net/d3/hp30203.htm>

IUFRO working group on nurseries. This site gives links to other useful sites.

<http://willow.ncfes.umn.edu/snti/snti.htm>

Home page of the USDA Forest Service's Seedling Nursery and Tree Improvement activity. It contains links to other mainly North American sites and holds the very useful Forest Nursery Notes:

[http://willow.ncfes.umn.edu/snti/fnn\\_list.htm](http://willow.ncfes.umn.edu/snti/fnn_list.htm)

The International Society for Horticultural Sciences (ISHS) is an international organization of horticultural producers and scientists. Its homepage is <http://www.ishs.org/> which contains links to other sites via <http://www.ishs.org/lin/linl.htm>.

Purdue University features a new crops section which can be visited through <http://www.hort.purdue.edu/newcrop>. This site leads you to the Australian New Crops Newsletter (<http://www.uq.oz.au/~gagkrego/newslett/l-newslet.htm>) which contains information about Australian underutilized or new crops, ranging from tree products to herbal plants.

The On-farm composting handbook provides useful tips about compost making: <http://www.cals.cornell.edu/dept/compost/OnFarmHandbook>

Cornell University's Department of Floriculture and Ornamental Horticulture has developed a manual for container-grown plants which contains useful information about substrates and fertilizing: <http://www.cals.cornell.edu/dept/flori/growon/index.html>.

The Texas Agricultural Extension Service has a web site which provides information of interest for tropical producers: <http://leviathan.tamu.edu>. Under [http://leviathan.tamu.edu: 70/ls/mg](http://leviathan.tamu.edu:70/ls/mg) you can find the 'Master Gardener' files which give leaf disease symptoms for a variety of tree species, amongst them a few tropical species.

The Henry Doubleday Research Association (<http://www.hdra.org.uk>) provides information about organic gardening and small scale production in tropical countries.

Another interesting site is <http://www.zoneten.com/nurserytoun.htm>. It belongs to a nursery in Florida with extensive experience in tropical plant propagation.

# Index

## A

acrylic as cover material for greenhouses, 68  
 alcohol, 58  
 animal waste products, 48

## B

bacterial moulds, 42  
 bare-root nursery, 22,58  
 bark, 34,38,40,42  
 biological control, 56,63  
 bleach, 57-58,60,61  
 bulk density, 31,34

C:N ratio, 39-40

*Calliandra calothyrsus*, 63

*Casuarinajunghuhniiana*, 33

cation exchange capacity (CEC), 33-34,36

charcoal, 38

chlorine, 57-58,60,61

cleanliness in the nursery, 62

client feedback, 16

coconut husks, 39,42

coefficient of variation (CV), 18-19

coffee shells, 39

compost, 39-41,42,48

container nursery, 22

containers, 22-29

copper coating of containers, 28

cover materials for greenhouses, 68

culling, 18,19

## D

damping-off, 56

day length, 71

direct sowing, 13

drip irrigation, 70

## £

electricity, 73

*Erythrina* spp., 63

experiments record, 74,76

## F

fertility, 33

fertilizer schedules, 50

fertilizers, 42,45-54

fertilizers, controlled-release, 51-53

fertilizers, granular, 49-51

fertilizers, inorganic, 49-53

fertilizers, organic, 47-49

fumigation, 58

fungicides, 61

*Fusarium* spp., 56

## G

gas exchange, 31,42,72-73

genetic base, 10

genetic quality, 9

germination trays, 13

glass, 68

*Gliricidia septum*, 63

gravel, 36,42,66

## H

hardening-off, 7,16,62

hydrogen peroxide, 58

*Inga edulis*, 33

inoculation, 13

integrated pest management, 56

irrigation, 69-70

ISTA (International Seed Testing Association), 11



**J**

jiffy pellets, 24

jiffy pots, 24

**L**

labelling of seed and nursery beds, 11

*Leucaena diversifolia*, 76-77

*Leucaena leucocephala*, 63, 76-77

*Leucaena trichandra*, 76-77

light quality, 71

**M**

macronutrients, 45-46

manure, 40,48

manure, nutrient content, 49

material flow chart, 66

methyl bromide, 59

micronutrients, 45,47

mist propagation, 69

mycorrhiza, 13

**N**

nursery bed density, 9

nursery calendar, 74-75, 77

nursery facilities, 65-73

nursery hygiene, 55-64

nursery inventory, 74,76

nursery layout, 66

nursery management, 74-78

**O**

osmocote controlled-release fertilizer, 51-53

overgrown plants, 16

**P**

peat, 34, 37-38

perlite, 34, 37

pest occurrence thresholds, 63

pesticides, 56, 63

pests, 69

pH,33

*Phytophthora* spp., 56, 60

plant density, 9,62

plant development register, 74-75

plant health status, 62

polybags, 23-25

polyester, 68

polyethylene, 67-68

polypropagator, 66-67

polysleeves, 23-25

polystyrene, 37

polytunnel, 66-67

polyvinyl chloride (PVC), 68

porosity, 31-32,42

pricking out, 13

propagation facilities, 57

*Prosopis chilensis*, 33

*Pythium* spp., 56, 60

**R**

*Rhizobium* spp., 13

*Rhizoctonia* spp., 56

rice hulls, 39,42

root deformities, 15

root system, 7, 14, 30

root trainers, 24-28,66

**S**

sand, 34,36,42

sawdust, 39,40,42

seed collection, 10

seed maturity, 10-11

seed ordering, 10

seed origin, 10

seed pre-treatment, 11,12

seed processing, 11

seed procurement, 9-11

seed storage, 11,12

seed storage, orthodox seed, 12

seed storage, recalcitrant seed, 12

seed supplier, 9,10

## INDEX

seed viability, 11  
seedling development, 12-17  
seedling quality, 7-21  
seedling variability, 17  
shade, 70  
shade cloth, 70-72  
shoot:root ratio, 8  
soil as entry point for pests, 58  
soil as potting substrate, 34  
soil fertility thresholds, 49  
soil pasteurization, 59  
soil sterilization, 58  
soil-less substrates, 35-39,45,50  
solarization, 59  
staff training, 62, 77  
steam pasteurization, 59  
sterilization of equipment, 57  
sturdiness quotient, 8  
substrates, 30-44  
substrates as entry point for pests, 58-59

substrates, chemical properties, 30, 33  
substrates, physical properties, 30-32  
substrates, plasticity, 31  
substrates, porosity, 31-32  
sugar cane bagasse, 39  
surface sterilization, 61

## T

target seedlings, 7  
*Tecoma starts*, 33  
temperature, 72  
tuff, 37

## V

vermiculite, 34, 36,42

## W

water holding capacity, 31-32  
water quality, 70



**DFID**



**ICRAF**



**CGIAR**

Supported by the  
Consultative  
Group on  
International  
Agricultural  
Research

**inifap**  
PRODUCE

**DSO**