

## Substrate quality

### *Physical and chemical properties of substrates*

Substrate quality is one of the most important influences on seedling growth. A good substrate has both the chemical and physical properties that promote healthy and rapid plant growth. These properties work together. A substrate that has many nutrients but is very heavy and does not allow the water to penetrate is not good. Similarly, a substrate that has adequate drainage, but is deficient in plant food, is not good.

The **physical properties** of the substrate include:

- how much water it can hold
- how much air space it contains
- its texture
- its weight per container.

The substrate must allow a large amount of water to be held without waterlogging. Air space (porosity) is necessary to allow air to enter and leave the substrate. The roots need to ‘breathe’, just as the leaves do. If the substrate holds too much water, the roots will suffocate.

The substrate texture is how it feels in your hand. Can you roll it into a ball then press it flat like a tortilla? Or is it gritty and crumbly? If you can roll it out, then it probably contains a lot of clay. High clay content may cause the substrate to shrink and crack when it dries. This can damage the root tips of the seedlings. If the texture is gritty, it probably contains a lot of sand, which adds porosity, but decreases the nutrient content and the ability of the substrate to hold water. Finally, the weight (bulk density) of the substrate affects how easily the seedlings can be transported to the field.

The **chemical properties** (‘fertility’) of the substrate include:

- the amount of nutrients it contains
- how easily available they are to the plants
- the rate at which they are released to the plants.

The fertility depends on the amount of nutrients — or plant food — in the substrate. Soil fertility is affected by the origin of the soil, and whether it has a lot of organic matter (see chapter 7). Soil from a forest or from close to a river usually has more nutrients than soil

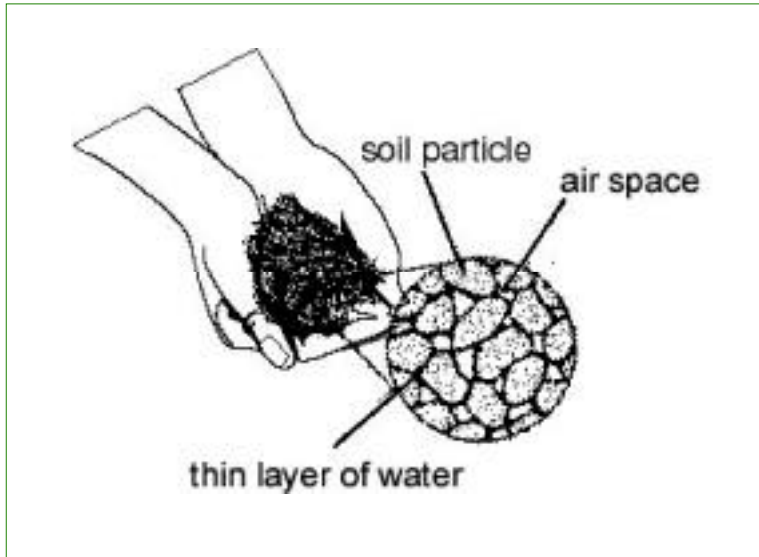

A good substrate has different size particles — this allows air and water to penetrate easily.

from cattle pastures. Soil from the top 10–15 cm is usually more fertile than soil from deeper down. Nutrient availability is regulated by how acidic the substrate is (measured in pH). Lemon is very acidic, chalk is very basic (or alkaline). The acidity can be adjusted by adding sulphur to increase acidity, or chalk to lower it. Rainwater is usually neutral, it is neither acidic nor basic. The rate of release of these nutrients is how quickly or slowly the soil releases these nutrients to the roots. In some soils, the nutrients are washed away quickly with each rain, in others, the nutrients are tightly bound to the soil and are difficult for the roots to extract.

A good nursery substrate has the following characteristics, the optimal substrate may vary for each species:

- it is light in weight to facilitate transport but holds cuttings and seedlings firmly in place
- it does not shrink or swell in a way that may damage the plants
- it retains water but allows proper drainage and aeration of the roots
- it contains the necessary nutrients to allow plant growth and development
- it does not contain weed seeds, high level of toxic salts, harmful fungi, bacteria or insects
- it can be sterilized without changing its characteristics
- its quality is consistent from year to year.

### 3 SUBSTRATE QUALITY

A *good nursery practice* is to mix soil with an inert (inactive) material like sand and a rich material such as well-decomposed organic matter. Because sand does not contain nutrients, you can leave it out entirely if a good compost is available. As general rule, the following mixtures are used in bare-root beds, or in bags, but not in root trainer containers (see chapter 4). The proportions are listed for the volume of each material. Mixing these materials also reduces soil mining.

	Soil	Sand	Compost
For heavy textured (clay) soils:	1	2	2
For medium textured (loam) soils:	1	1	1
For light textured (sand) soils:	1	0	1

#### **Soil mining**

Soil mining — excavating soil — for the nursery can cause erosion and site degradation. When soil is used, the fertile, upper layers are quickly depleted, leaving poor quality subsoil. In Mexico, 25 million m<sup>3</sup> of soil are used every year in tree nurseries. The area where the soil was taken loses nutrients that took decades if not longer to acquire. Trees and crops do not grow well in an area where soil has been mined. As soil is depleted, the costs of buying and transporting soil rise for the nursery.

#### **Adding beneficial fungi and bacteria**

Many tree species have a special symbiosis, or mutually beneficial relationship between a fungus and the tree roots. This intimate association is called a ‘mycorrhiza’. Many different kinds of fungi occur in this form, and different fungi work best for each tree species. The association helps the plant absorb water and nutrients, and protects the roots from diseases.

When growing pines, oaks or eucalypts it is important to inoculate the roots with the appropriate fungus. This is especially important if these species are being produced in an area for the first time. If they are not inoculated, the trees will be yellow and stunted and grow poorly or die in the field. The easiest way to ensure presence of the beneficial mycorrhizal

fungi is to collect soil from healthy, existing plantations of these species, and mix the soil into the nursery substrate. The mixture should contain up to 10% of the plantation or forest soil.

Similarly, many legume trees also require special bacteria called ‘rhizobia’, to use nitrogen, one of the most important nutrients (see chapter 7). Inoculation with these bacteria is necessary on acidic soils where legumes have not been planted before. Without inoculation with rhizobia, the plants may not grow at all or may be severely stunted. Many different strains are available and some may be more effective than others. Rhizobia for beans are commonly available at agrochemical stores. You may have to try several types before you find the correct type for your nursery trees. Keep the bacteria out of direct sunlight, store in a cool dry place, and use as soon as possible. Otherwise they will die and the supply will become useless. The living bacteria are mixed directly with seed before planting.

A *good nursery practice* is to apply mycorrhizal fungi or rhizobial bacteria, or both in the case of legumes, after sterilizing the soil. Heat and chemical sterilization can kill these beneficial micro-organisms.

#### ***Legumes — plants that produce their own nitrogen***

Legumes are a special family of plants that have bacteria growing in their roots. Legumes include beans, and many trees that produce seeds in pods, such as leucaena and calliandra. You can see the areas where bacteria live as little nodules or bundles on the roots. The bacteria allow the plants to use nitrogen gas that is in the air and between soil particles. Other plants can only take nitrogen that is dissolved in the water in the soil. Making use of the unique collaboration between plants and bacteria, legumes can acquire more nitrogen than other plants. Legumes make a good green manure or ‘living fertilizer’, because they add nitrogen to the soil.

#### ***Organic matter is a treasure***

Organic matter is derived from once-living plant or animal matter. It includes leaves, weeds, and animal waste. Organic matter must be well-decomposed, or broken down, and produce no odour or heat, before incorporating into the substrate. Unfortunately, many people think of organic matter as trash or waste (commonly called ‘basura’ in Spanish). ***A poor, but unfortunately common nursery practice*** is to burn organic matter. The burning of organic debris in the nursery (with exception of diseased plants) is a terrible loss of valuable, rich material.

### 3 SUBSTRATE QUALITY

Organic matter is in fact not waste at all — the opposite is true, it is a useful source of nursery compost. *Organic matter may be one man's trash, but to the nursery, it is a treasure.* Organic matter can greatly improve the substrate's chemical and physical properties necessary for good plant growth. It provides plant nutrients, improves porosity and water-holding capacity, and makes the substrate lighter and easier to transport. In fact, a well-decomposed compost can actually help suppress plant diseases like damping-off. Of course, it also reduces soil mining! The idea of using compost is not new — it comes from

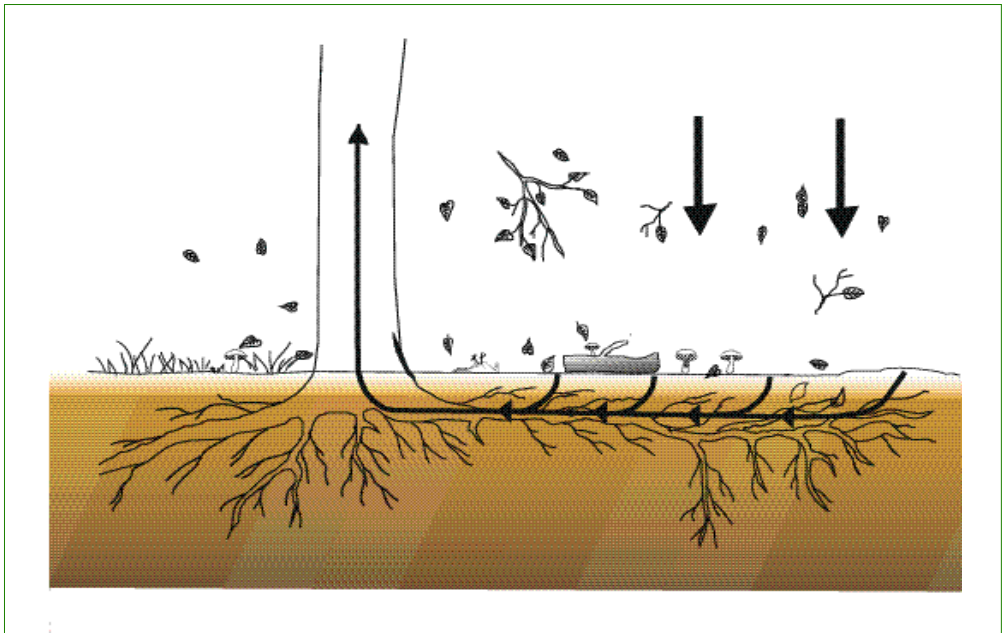

nature. Nature produces and uses compost all the time. When organic debris falls to the ground, it decomposes with the help of fungi and other micro-organisms living near the soil surface. The finished compost or humus is then reabsorbed by the plant roots. This is a perfect recycling system for plant nutrients.

#### ***What happens during composting?***

Composting is the physical and chemical breakdown of materials. It liberates nutrients available to plants. Insects, fungi, and bacteria digest material during decomposition. They must 'eat' all of the material before it becomes finished compost. They need air and water to do this well.

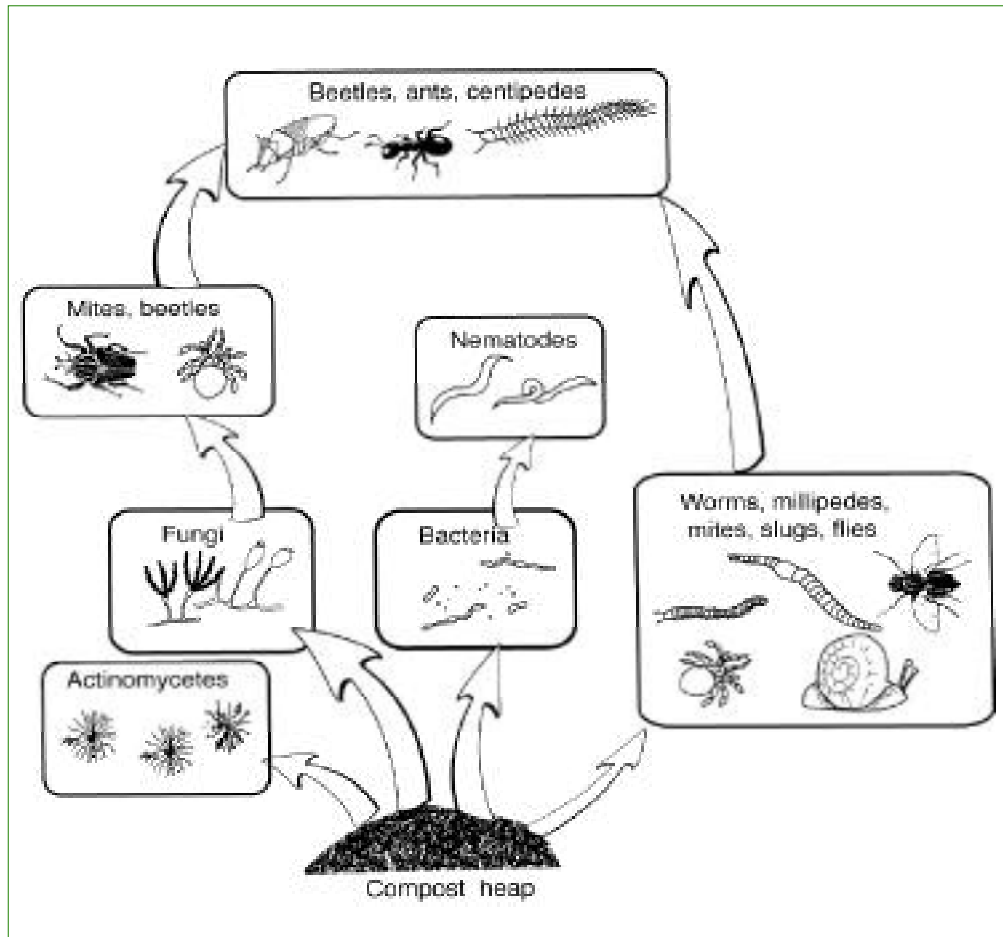

A compost pile is alive with many organisms that eat the organic material. Many are too small to be seen, but they are all important in breaking down the organic matter and turning it into compost.

There are two basic ways of compost production: anaerobic and aerobic. Anaerobic methods supply minimum oxygen to the micro-organisms digesting the organic material in the heap, while aerobic methods supply maximum oxygen. The main differences between the two are time and odour. Anaerobic composting is very slow, and usually takes more than nine months. Anaerobic composting uses less labour because pits are filled with material, covered and left unattended. However, foul smelling gases (methane and sulphur) often develop.

Aerobic compost can be ready in as little as 40 days if it is regularly turned. Aerobic composting also requires regular monitoring of the temperature to ensure the best possible conditions for the most effective micro-organisms. We will only discuss aerobic composting because it is faster and more reliable.

Three distinct phases based on temperature development occur during composting. The heat comes from the proliferation of the micro-organisms — they are working hard and reproducing which causes heat, just as when people work, they get hot, thirsty and needs lots of fresh air and water. Efficient composting is all about creating the right microhabitat — the right ‘house’ or ‘office’ — so that the micro-organisms can proliferate (reproduce) and work hard (digest the organic material).

During the first 24 to 48 hours, the temperature rises to 40–50°C, destroying sugars and other easily biodegradable substances. During the second phase, as the temperature rises to 55–65°C, the initial micro-organisms die, and others specially adapted to the heat begin to break down the more difficult material, like cellulose (a component of wood). The temperature should reach a peak of 70°C for three days to kill all weed seeds and plant diseases. Keeping the temperature between 55 and 65°C as long as possible is the fastest way to produce compost because this is the phase when the most efficient micro-organisms are breaking down the hardest to digest material. Turning the pile to incorporate oxygen and ensure an even distribution of the materials and maintaining 40–60% moisture allows for optimal composting efficiency. The final stage, in which the temperature remains below 40°C, is called ‘maturing’ or ‘curing’, because the bacteria and fungi that help control plant diseases, as well as the larger organisms like earthworms, move in.

Good compost should be ‘old’ and well-decomposed. Young compost, which might not be completely decomposed or broken down, can harm tree seedlings. Trees planted with unfinished compost often turn yellow, because the plant cannot acquire all the nutrients it needs. To see whether compost is ready, place two moist handfuls in a plastic bag, seal it and leave in a dark, cool place. After 24 hours open the bag: if no odour or heat is present, the compost is ready. You should not be able to recognize the original material, such as an entire leaf or an orange peel. It should have the consistency and colour of coarsely ground coffee. You can then sieve the compost and return any large particles to the next compost batch.

#### ***The right ingredients for compost***

Each batch will differ depending on the materials you use. Producing consistently good compost takes some practice, but is important for consistently producing high quality

trees. Not all tree species will respond in the same way to the compost, so some adjustments may be necessary. A **good nursery practice** is to plan ahead and start making compost well before you need it. It is very important to realize that only about 40% of the fresh material by volume will become finished compost. Therefore, obtaining large quantities of fresh material at minimal costs is essential for efficient and economical composting.

Any organic material can be composted; a mixture of materials is best. Depending on what is available in your area, grass, leaves, any fruits or fruit waste (like peels) from plantations, coconut fibres, coffee shells, sugar cane bagasse, and rice hulls can be used. Weeds and old seedlings, as long as they are not diseased, can also be included. In addition, animal manure from cows, horses, goats, chickens etc. should be added at about 25% of the total volume because it contains a lot of nitrogen. Feathers and even human hair can be used because they are high in nitrogen. Diseased plants should always be removed from the nursery and burned. A **good nursery practice** is to test a variety of organic materials to find the right mixture for each species.

**Plan ahead  
and start  
making  
compost  
well before  
you need it.**

**Test a variety  
of organic  
materials to  
find the right  
mixture for  
each species.**

A ‘compost bank’ is an area planted with a variety of ‘crops’ such as sugarcane and legumes like canavalia (*Canavalia* spp.), nescafé (*Mucuna pruriens*), poró (*Erythrina* spp.) or madera negra (*Gliricidia* spp.). It is similar to a fodder bank that farmers plant for animals. It provides a consistent supply of organic matter and is easy to harvest. Over time, it may be necessary to fertilize this area, since the nutrients from the soil are ‘exported’ with the crops.

Material that is chopped, shredded, or cut into small pieces (ideally, 1–2 cm) with machetes or a mechanical shredder is easier for micro-organisms to break down. This makes decomposition faster and produces a more homogeneous mixture for filling containers.

Adding lime (calcium carbonate) is not generally recommended since it will make the compost too basic. Too much lime will also kill the micro-organisms. Adding fertilizer may speed up the process, and improve the nutrient content of the compost, but it is not necessary — and defeats the purpose of producing your own cheap fertilizer! Finished compost can be mixed with soil later, but soil and sand should not be added while making the compost. This only slows the composting process and wastes space in the composting bed. For the method described below, compost improves soil, but soil does not improve compost.



#### ***Be careful with sawdust!***

Sawdust is frequently mixed with soil because it is cheap and readily available, but even old sawdust can be a problem. Sawdust and wood chips are very difficult for micro-organisms to digest because they contain the same chemicals that make the wood hard and resistant to rain. The sawdust often does not contain many nutrients, specifically, nitrogen, an essential plant nutrient. Plants grown in sawdust become yellow, unless nitrogen is applied. Nitrogen is found in many granular fertilizers, the strongest of which is urea, and in animal manure. Mixing nitrogen with the sawdust can make a good nursery substrate, however, several tests are necessary to find the right proportions because the characteristics of the sawdust vary with species and age. Try mixing a total of 3–4 kg of N in the form of urea per cubic metre of sawdust during three applications one month apart. If you use N from a different source, for example, 17-17-17, you will need to apply more because the N concentration is not as strong as in urea.

#### ***The ‘three bed system’ for making compost***

There are many ‘recipes’ for making compost depending upon the climate and the materials available. It is best to experiment until you find what works best for you. This aerobic method produces compost in 2–4 months in the humid tropics. It uses less labour and time than compost made in a pit because the compost is kept well-aerated above the ground at all times and is easier to mix.

In a flat area, make three rectangles (3 m long 1.5 m wide) side by side with large bricks, rocks or large wooden beams (at least 30 cm off the ground). Put some bricks in the centre for extra support. Allow at least 1 metre between the rectangles as a path for working. Don’t make them too wide, or they will not support the weight of the compost. However, they can be as long as you want. On top of this base, construct a flat ‘bed’ with bamboo, wood, or metal poles. Choose a material that will not rot quickly. Chicken wire or palm leaves are very useful for covering the bed. The bed should have some holes or cracks to allow air to pass through — but not big enough for the compost to fall through.

Pile organic material to about 1 metre tall on the two outer beds. Leave the middle bed empty. Keep the piles flat, not pointed like a pyramid, in order to use the space more efficiently. After a week, the compost should become very warm. Check the temperature by placing

your hand deep inside the pile at two or three locations. It should feel warm to the touch. After the temperature drops again, in about another two weeks, use pitchforks to lightly loosen the material in each bed. This adds oxygen for the micro-organisms. After another two weeks, carefully move the material from the outside of each compost pile to the empty centre

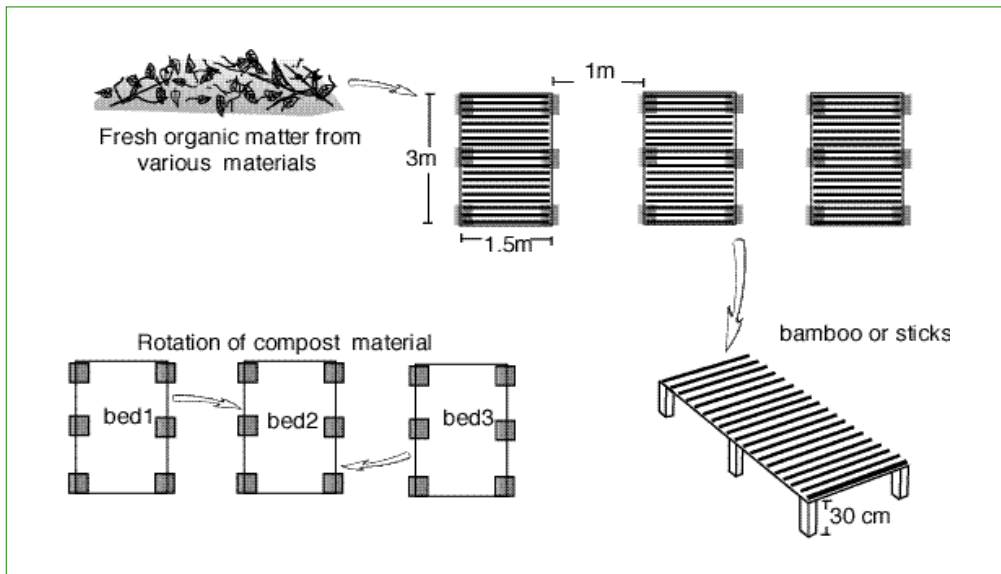

The three bed system works rapidly because air passes below the beds. The process is also labour efficient because turning is made easy.

bed. Then remove the next layer of compost and put it on the centre bed, on top of what's already been moved. This mixes the pile, putting the material from the outside into the inside of the pile. After a week, the compost in the centre pile should become warm again. The outer two beds are ready to fill again with fresh material as soon as you have moved the piles to the central bed.

Always monitor the moisture status of the piles. Add water when dry, or build a roof if too much rainwater enters the piles. A *good nursery practice* is to keep the pile well-aerated, and moist at all times. Putting a plastic sheet, coconut leaves, or other covering over the piles helps conserve the water if the climate is particularly dry. After four weeks move the compost from the middle bed to a storage area. This allows it to mature

**Keep the pile well-aerated, and moist at all times. Monitor it frequently.**

or ripen; the chemical components of the compost will become stable. Carefully cover it, but don't seal it entirely — allow some holes so that the compost can breathe. Covering it will prevent weed seeds from landing on the finished compost. The other two beds should be ready to combine into the middle bed when you move the finished compost to a storage area, and the process can start again.

#### ***The most common problems in compost making***

Once you understand the basics, practice will determine your success. A *good nursery practice* is to monitor the compost frequently. It cannot be left alone and expected to produce good, rich compost without any effort.

- If the pile smells acidic or like rotten eggs, the compost is anaerobic. Loosen the heap with a pitchfork to improve the aeration.
- If the pile is very wet or very dry, cover loosely with a plastic sheet. It should contain about 50% water. It should be moist when squeezed in your hand, like a wrung-out sponge, but water should not drip out.
- The pile may not heat up, if it is too wet or too dry or if the wrong materials — such as mostly woody branches — are used.
- The pile may not heat up or decomposition may be very slow, if it is not homogeneously mixed. Look for parts that are too wet or too dry or contain just one type of material and then mix well.

#### ***A compost pile is not a rubbish pile. Never add:***

- glass
- metal
- plastic (including left-over bags from the seedlings)
- meat (it will attract rodents and dogs).

#### ***Calculating substrate quantity***

First, determine the volume of the container. Cover the holes of the container and add water from a litre bottle. The amount of water you add is equal to the volume. Small bags usually hold  $\frac{1}{2}$  litre of water, large bags may hold more than 1.5 litres. Root trainers usually have a volume of less than  $\frac{1}{2}$  litre. A normal size bucket holds 20 litres – enough to fill 40 small bags or 13 big ones.

Second, multiply the volume of your container by the number of seedlings to be produced.

Finally, divide the resulting volume by 20, the capacity of one big bucket, to see how many buckets of substrate you need to fill all containers.

**Example One.** If 10,000 seedlings are needed and  $\frac{1}{2}$  litre (0.5 litre) bags are used:  
 $10,000 \times 0.5 = 5000$  litres of substrate  
 $5000 / 20 = 250$  buckets

**Example Two.** If 2000 seedlings are produced in 1 litre containers:  
 $2000 \times 1 = 2000$  litres of substrate  
 $2000 / 20 = 100$  buckets

When using compost, a general rule is that fresh compost has twice the volume of finished compost. This may vary depending on the material used.

First, calculate the total volume of each bed. For example, if you have three beds of fresh compost and each bed is 3 metres long, 1.5 metres wide and one metre high, then multiply:

$$3 \text{ m} \times 1.5 \text{ m} \times 1 \text{ m} = 4.5 \text{ m}^3 \times 3 \text{ beds} = 13.5 \text{ m}^3 \text{ of fresh material}$$

Second, divide this number by 2, for the total amount of finished compost.

$$13.5 \text{ m}^3 / 2 = 6.75 \text{ m}^3 \text{ (6750 litres or 338 buckets) of finished compost.}$$

**Example Three.** If you want to produce the 10,000 plants from example 1 with a mixture of 1:1 soil:compost, you will need 2500 litres of finished compost, or 5000 litres ( $5 \text{ m}^3$ ) of fresh compost.

If the fresh compost reduces its volume by only 30%, then less fresh compost is needed. Similarly, if your mixture contains less compost, say in a 2:1 soil:compost mixture, less finished compost is needed.

#### ***Summary of substrate quality***

Substrate quality is determined by both the physical characteristics such as good drainage, and chemical characteristics such as high nutrient content. A good nursery substrate is light, retains water, but does not become waterlogged, and does not contain weed seeds or harmful micro-organisms. Organic matter is a valuable treasure because it improves substrate quality. Composting is the controlled breakdown of organic matter that provides a good alternative to soil mining.

#### ***Good nursery practices***

- improve the substrate physical and chemical characteristics with compost
- add beneficial mycorrhizae and rhizobia after sterilizing the substrate
- plan ahead and start the compost well before you need it
- test a variety of organic materials to find the right mixture for each species
- keep the compost pile well-aerated and moist at all times
- monitor the compost frequently

#### ***Poor, but unfortunately common nursery practices***

- burning of organic matter
- mixing glass, metal, plastic or meat into the compost pile